

MCS-XV



MCS-XV-RM



MCS-XV-DT

TECHNICAL MANUAL

EM0256-07

Dear user,

The information contained in this technical manual was current as the time of printing and applies to specific versions.

Changes may be made for the purpose of continuous products improvement.

Yours sincerely,
Presys Instrumentos e Sistemas

IMPORTANT RECOMMENDATIONS:

- The fuse (code 01.02.0277-21) that protects the current circuit is a special component. Therefore, only replace it with another original in order not to impair the accuracy of the ISOCAL MCS-XV.
- When not in daily use, respect the minimum warm-up time of one hour.
- In case of calibrator failure, contact Technical Assistance.



**The warranty conditios are available on our site:
www.presys.com.br/warranty**

Summary

1. INTRODUCTION	1
1.1. General Description	1
1.2. Specifications - Inputs	2
1.3. Specifications - Output	5
1.4. Optional Items	8
1.5. General Specifications	10
1.6. Special Software Features	13
1.7. Order Code	14
2. OPERATION	15
2.1. Parts Identification	15
2.2. Battery and Charger (only for MCS-XV Portable Version)	20
2.3. Using MCS-XV: Basic Functions	22
2.4. Calibrator	23
2.4.1. Measure or Input Functions	25
2.4.2. Generation or Output Functions	39
2.4.3. Available Power Supplies	45
2.4.4. Input Special Functions	46
2.4.5. Output Special Functions	50
2.4.6. Saving Current Configuration (Memory Manager)	55
2.4.7. AD/Ratio	57
2.4.8. Bargraph	58
2.4.9. Calibration Examples	60
2.5. HART [®]	65
2.5.1. HART [®] Connections	65
2.5.2. Starting Communication	69
2.5.3. Adjusting the Measurement Range of a HART [®] Transmitter (CH Option)	71
2.5.4. Adjusting the Measurement Range of a HART [®] Transmitter with Reference (CH Option)	72

2.5.5. HART® Transmitter mA Output Adjustment	74
2.5.6. FULL HART® Configurator (FH)	76
2.6. Profibus®	81
2.6.1. Profibus® Communication	82
2.7. <i>Data Logger</i>	91
2.8. Automatic Tasks	93
2.8.1. Creating Tasks	93
2.8.2. Executing Tasks	98
2.8.3. Viewing Results	99
2.8.4. Task Advanced Options	103
2.9. <i>Help Desk</i>	104
3. SETTINGS	107
3.1. Date and Time	107
3.2. Network	108
3.2.1. Naming the Calibrator	109
3.2.2. Altering the IP Address	109
3.2.4. Viewing IP Address	110
3.3. Services	111
3.3.1. Remote Access	112
3.3.2. Serial Communication	114
3.3.3. File sharing and USB host control	116
3.3.4. Server Communication	117
3.4. SYSTEM	118
3.4.1. Touchscreen Options	118
3.4.2. Screen Brightness	118
3.4.3. Calibrator Identification	119
3.4.4. Print Configuration	119
3.4.5. Security Options	119
3.4.6. Adjust Cal.	121

4. ADJUST	122
4.1. Inputs Adjustment	124
4.1.1. V, mV, and mA Inputs	124
4.1.2. OHMS Input	126
4.1.3. CJC Adjustment	126
4.2. Outputs Adjustment	127
4.2.1. V, mV, and mA Outputs	127
4.2.2. OHM Output	127
4.2.3. Probe Adjustment.....	128
5. PRESSURE SENSOR INSTALLATION AND ADJUSTMENT	130
5.1. Installation.....	131
5.2. Parameters Configuration	133
5.2.1. Sensor Information.....	133
5.2.2. mV Adjustment.....	136
5.2.3. Pressure Adjustment.....	138
6. MAINTENANCE	140
6.1. Battery Replacement (Only for portable MCS-XV)	140
6.2. Battery Calibration (Only for portable MCS-XV)	142
6.3. Replacement of the Current Input Fuse.....	146
7. PRESSURE UNITS CONVERSION.....	148

1. INTRODUCTION

1.1. General Description

The MCS-XV calibrator allows the measurement and generation of signals used in instrumentation and process control. It is designed to offer the necessary resources to facilitate the work of keeping the process instruments adjusted and calibrated. It has elevated levels of accuracy, including aspects related to changes in room temperature and maintenance of specifications over prolonged periods.

Its Portable version considers the use in the field, thus includes items of great value such as: bag with shoulder straps allowing freedom for hands, display of 5.7" *with led backlight* facilitating *visibility* in environments with low lighting, rechargeable battery, and large memory capacity to store the values obtained allowing the transfer of these to the computer, when necessary. In addition to these, several constructive factors can be mentioned that add quality and efficiency to the MCS-XV, including foresee its use not only in the field but also in the bench (**RM** Version - *Rack Mounting*, **DT** Version - *Desktop*).

Incorporates the newest concepts of union of adjustments and calibrations with Information Technology, where data is shared by both the instrument and the computer, giving efficiency to the processing of information, in the form of reporting and certificates, the automated management of tasks and the organization and archiving of data, that is, covers a whole context aimed at compliance with quality procedures, mainly related to ISO-9000 standard. It also has HART® communication (optional) for reading and configuring parameters of field devices which have this protocol.

Can be supplied with up to four pressure outlets. Thus, in a single calibrator, it is possible to use different pressure ranges, for example: vacuum, 0 to 100 psi, 0 to 1000 psi and 0 to 3000 psi or any other combination of available de ranges. It can also be purchased with a certain number of pressure sensors, which may be later increased. To add pressure sensors beyond those available in the calibrator, there is the possibility of acquiring an external pressure module (MPYA) that communicates with the MCS-XV via USB port.

Another option is a high-accuracy sensor that, among its numerous functions, can function as standard thermometer. Thus, while indicating the reference temperature, it allows the calibration of another temperature sensor.

1.2. Specifications - Inputs

Input Ranges	Resolution	Accuracy	Remarks
millivolt -500 mV to -150 mV -150 mV to 150 mV 150 mV to 2450 mV	0.01 mV 0.001 mV 0.01 mV	$\pm 0.02\%$ FS* $\pm 0.01\%$ FS $\pm 0.02\%$ FS	$R_{input} > 10\text{ M}\Omega$ auto-ranging
volt -10 V to 11 V 11 V to 45 V	0.0001 V 0.0001 V	$\pm 0.02\%$ FS $\pm 0.02\%$ FS	$R_{input} > 1\text{ M}\Omega$
mA -5 mA to 24.5 mA	0.0001 mA	$\pm 0.01\%$ FS	$R_{input} < 120\ \Omega$
resistance 0 to 400 Ω 400 to 2500 Ω	0.01 Ω 0.01 Ω	$\pm 0.01\%$ FS $\pm 0.03\%$ FS	Excitation current 0.85 mA, auto-ranging
frequency ** 0 to 600 Hz 600 to 1300 Hz 1300 to 5000 Hz	0.01 Hz 0.1 Hz 1 Hz	$\pm 0.04\text{ Hz}$ $\pm 0.2\text{ Hz}$ $\pm 2\text{ Hz}$	$R_{input} > 50\text{ k}\Omega$ Voltage DC $_{max} = 30\text{ V}$ AC Signal from 0.3 to 30 V auto-ranging
counter ** 0 to $10^8 - 1$ count	1 count	-----	Same as frequency. Pulse frequency $< 3000\text{ Hz}$

(*) FS = Full Scale.

(**) Function available since the frequency output is not configured.

	Input Ranges	Resolution	Accuracy	Remarks
Pt-100	-200 to 850 °C / -328 to 1562 °F	0.01 °C / 0.01 °F	± 0.1 °C / ± 0.2 °F	IEC 60751
Pt-1000	-200 to 400 °C / -328 to 752 °F	0.1 °C / 0.1 °F	± 0.1 °C / ± 0.2 °F	IEC 60751
Cu-10	-200 to 260 °C / -328 to 500 °F	0.1 °C / 0.1 °F	± 2.0 °C / ± 4.0 °F	Minco 16-9
Ni-100	-60 to 250 °C / -76 to 482 °F	0.1 °C / 0.1 °F	± 0.2 °C / ± 0.4 °F	DIN-43760
probe*	-200 to 850 °C / -328 to 1562 °F	0.01 °C / 0.01 °F	± 0.1 °C / ± 0.2 °F	IEC 60751
TC-J	-210 to 1200 °C / -346 to 2192 °F	0.1 °C / 0.1 °F	± 0.2 °C / ± 0.4 °F	IEC 60584
TC-K	-270 to -150 °C / -454 to -238 °F	0.1 °C / 0.1 °F	± 0.5 °C / ± 1.0 °F	IEC 60584
TC-K	-150 to 1370 °C / -238 to 2498 °F	0.1 °C / 0.1 °F	± 0.2 °C / ± 0.4 °F	IEC 60584
TC-T	-260 to -200 °C / -436 to -328 °F	0.1 °C / 0.1 °F	± 0.6 °C / ± 1.2 °F	IEC 60584
TC-T	-200 to -75 °C / -328 to -103 °F	0.1 °C / 0.1 °F	± 0.4 °C / ± 0.8 °F	IEC 60584
TC-T	-75 to 400 °C / -103 to 752 °F	0.1 °C / 0.1 °F	± 0.2 °C / ± 0.4 °F	IEC 60584
TC-B	50 to 250 °C / 122 to 482 °F	0.1 °C / 0.1 °F	± 2.5 °C / ± 5.0 °F	IEC 60584
TC-B	250 to 500 °C / 482 to 932 °F	0.1 °C / 0.1 °F	± 1.5 °C / ± 3.0 °F	IEC 60584
TC-B	500 to 1200 °C / 932 to 2192 °F	0.1 °C / 0.1 °F	± 1.0 °C / ± 2.0 °F	IEC 60584
TC-B	1200 to 1820 °C / 2192 to 3308 °F	0.1 °C / 0.1 °F	± 0.7 °C / ± 1.4 °F	IEC 60584

(*) **Probe** is an input for a reference RTD to use as standard thermometer. The accuracy is related Only to MCS-XV.

Input Ranges	Resolution	Accuracy	Remarks
TC-R -50 to 300 °C / -58 to 572 °F	0.1 °C / 0.1 °F	± 1.0 °C / ± 2.0 °F	IEC 60584
TC-R 300 to 1760 °C / 572 to 3200 °F	0.1 °C / 0.1 °F	± 0.7 °C / ± 1.4 °F	IEC 60584
TC-S -50 to 300 °C / -58 to 572 °F	0.1 °C / 0.1 °F	± 1.0 °C / ± 2.0 °F	IEC 60584
TC-S 300 to 1760 °C / 572 to 3200 °F	0.1 °C / 0.1 °F	± 0.7 °C / ± 1.4 °F	IEC 60584
TC-E -270 to -150 °C / -454 to -238 °F	0.1 °C / 0.1 °F	± 0.3 °C / ± 0.6 °F	IEC 60584
TC-E -150 to 1000 °C / -238 to 1832 °F	0.1 °C / 0.1 °F	± 0.1 °C / ± 0.2 °F	IEC 60584
TC-N -260 to -200 °C / -436 to -328 °F	0.1 °C / 0.1 °F	± 1.0 °C / ± 2.0 °F	IEC 60584
TC-N -200 to -20 °C / -328 to -4 °F	0.1 °C / 0.1 °F	± 0.4 °C / ± 0.8 °F	IEC 60584
TC-N -20 to 1300 °C / -4 to 2372 °F	0.1 °C / 0.1 °F	± 0.2 °C / ± 0.4 °F	IEC 60584
TC-L -200 to 900 °C / -328 to 1652 °F	0.1 °C / 0.1 °F	± 0.2 °C / ± 0.4 °F	DIN-43710
TC-C 0 to 1500 °C / 32 to 2732 °F	0.1 °C / 0.1 °F	± 0.5 °C / ± 1.0 °F	W5Re / W26Re
TC-C 1500 to 2320 °C / 2732 to 4208 °F	0.1 °C / 0.1 °F	± 0.7 °C / ± 1.4 °F	W5Re / W 26Re

1.3. Specifications - Output

	Input Ranges	Resolution	Accuracy	Remarks
	millivolt -10 mV to 110 mV	0.001 mV	± 0.02 % FS	$R_{\text{output}} < 0.3 \Omega$
	volt -0.5 V to 12 V	0.0001 V	± 0.02 % FS	$R_{\text{output}} < 0.3 \Omega$
	mA 0 to 24 mA	0.0001 mA	± 0.02 % FS	$R_{\text{max}} = 700 \Omega$
	(XTR) 2-wire Transmitter 4 mA to 24 mA	0.0001 mA	± 0.02 % FS	$V_{\text{max}} = 60 \text{ V}$
	Resistance 0 to 400 Ω 0 to 2500 Ω	0.01 Ω 0.1 Ω	± 0.02 % FS ± 0.03 % FS	For external excitation current of 1.0 mA
	Frequency* 0 to 100 Hz 0 to 10000 Hz	0.01 Hz 1 Hz	± 0.02 Hz ± 2 Hz	Peak value: 22 V / 25 mA max.
	Pulse* 0 to 10^5 - 1 pulse	1 pulse	-----	Peak value: 22 V / 25 mA max. Pulses frequency up to 10000 Hz
	Pt-100 -200 to 850 °C / -328 to 1562 °F	0.01 °C / 0.01 °F	± 0.2 °C / ± 0.4 °F	IEC 60751
	Pt-1000 -200 to 400 °C / -328 to 752 °F	0.1 °C / 0.1 °F	± 0.1 °C / ± 0.2 °F	IEC 60751
	Cu-10 -200 to 260 °C / -328 to 500 °F	0.1 °C / 0.1 °F	± 2.0 °C / ± 4.0 °F	Minco 16-9
	Ni-100 -60 to 250 °C / -76 to 482 °F	0.1 °C / 0.1 °F	± 0.2 °C / ± 0.4 °F	DIN-43760

(*) Function available since the frequency input is not configured.

Input Ranges	Resolution	Accuracy	Remarks
TC-J -210 to 1200 °C / -346 to 2192 °F	0.1 °C / 0.1 °F	± 0.4 °C / ± 0.8 °F	IEC 60584
TC-K -270 to -150 °C / -454 to -238 °F	0.1 °C / 0.1 °F	± 1.0 °C / ± 2.0 °F	IEC 60584
TC-K -150 to 1370 °C / -238 to 2498 °F	0.1 °C / 0.1 °F	± 0.4 °C / ± 0.8 °F	IEC 60584
TC-T -260 to -200 °C / -436 to -328 °F	0.1 °C / 0.1 °F	± 1.2 °C / ± 2.4 °F	IEC 60584
TC-T -200 to -75 °C / -328 to -103 °F	0.1 °C / 0.1 °F	± 0.8 °C / ± 1.6 °F	IEC 60584
TC-T -75 to 400 °C / -103 to 752 °F	0.1 °C / 0.1 °F	± 0.4 °C / ± 0.8 °F	IEC 60584
TC-B 50 to 250 °C / 122 to 482 °F	0.1 °C / 0.1 °F	± 5.0 °C / ± 10.0 °F	IEC 60584
TC-B 250 to 500 °C / 482 to 932 °F	0.1 °C / 0.1 °F	± 3.0 °C / ± 6.0 °F	IEC 60584
TC-B 500 to 1200 °C / 932 to 2192 °F	0.1 °C / 0.1 °F	± 2.0 °C / ± 4.0 °F	IEC 60584
TC-B 1200 to 1820 °C / 2192 to 3308 °F	0.1 °C / 0.1 °F	± 1.4 °C / ± 2.8 °F	IEC 60584
TC-R -50 to 300 °C / -58 to 572 °F	0.1 °C / 0.1 °F	± 2.0 °C / ± 4.0 °F	IEC 60584
TC-R 300 to 1760 °C / 572 to 3200 °F	0.1 °C / 0.1 °F	± 1.4 °C / ± 2.8 °F	IEC 60584
TC-S -50 to 300 °C / -58 to 572 °F	0.1 °C / 0.1 °F	± 2.0 °C / ± 4.0 °F	IEC 60584
TC-S 300 to 1760 °C / 572 to 3200 °F	0.1 °C / 0.1 °F	± 1.4 °C / ± 2.8 °F	IEC 60584
TC-E -270 to -150 °C / -454 to -238 °F	0.1 °C / 0.1 °F	± 0.6 °C / ± 1.2 °F	IEC 60584
TC-E -150 to 1000 °C / -238 to 1832 °F	0.1 °C / 0.1 °F	± 0.2 °C / ± 0.4 °F	IEC 60584

Input Ranges	Resolution	Accuracy	Remarks
TC-N -260 to -200 °C / -436 to -328 °F	0.1 °C / 0.1 °F	± 2.0 °C / ± 4.0 °F	IEC 60584
TC-N -200 to -20 °C / -328 to -4 °F	0.1 °C / 0.1 °F	± 0.8 °C / ± 1.6 °F	IEC 60584
TC-N -20 to 1300 °C / -4 to 2372 °F	0.1 °C / 0.1 °F	± 0.4 °C / ± 0.8 °F	IEC 60584
TC-L -200 to 900 °C / -328 to 1652 °F	0.1 °C / 0.1 °F	± 0.4 °C / ± 0.8 °F	DIN-43710
TC-C 0 to 1500 °C / 32 to 2732 °F	0.1 °C / 0.1 °F	± 0.5 °C / ± 1.0 °F	W5Re / W26Re
TC-C 1500 to 2320 °C / 2732 to 4208 °F	0.1 °C / 0.1 °F	± 0.7 °C / ± 1.4 °F	W5Re / W 26Re



Accuracy values are valid within one year and temperature range of 20 to 26 °C. Outside these limits add 0.001 % FS / °C taking 23 °C as the reference temperature. For thermocouples, using the internal cold junction compensation add a cold junction compensation error of ± 0.2 °C or ± 0.4 °F max.

1.4. Optional Items

Pressure Sensors

Can be placed up to 4 (four) pressure sensors in MCS-XV, with ranges between 250 mmH₂O and 10,000 psi.

Ranges*	Resolution	Accuracy**	Remarks
(0) 0 – 25 mbar	0.0001	± 0.05 % FS**	Gauge pressure Use with air or inert gases.
(1) 0 – 70 mbar	0.001	± 0.05 % FS	
(2) 0 – 350 mbar	0.01	± 0.025 % FS	
(3) 0 – 1 bar	0.00001	± 0.025 % FS	Gauge or absolute pressure. Use with fluids (Gases or liquids) Compatible with INOX 316 L stainless steel.
(4) 0 – 2 bar	0.00001	± 0.025 % FS	
(5) 0 – 7 bar	0.0001	± 0.025 % FS	
(6) 0 – 20 bar	0.0001	± 0.025 % FS	
(7) 0 – 35 bar	0.001	± 0.025 % FS	
(8) 0 – 70 bar	0.001	± 0.025 % FS	
(9) 0 – 210 bar	0.001	± 0.025 % FS	
(10) 0 – 350 bar	0.01	± 0.025 % FS	
(11) 0 – 700 bar	0.01	± 0.05 % FS	
(12) Others under request			

(*) Gauge pressure, absolute (from range 3 to 8), vacuum (only for range 3), compound (from range 3 to 8) and differential (from range 0 to 2).

(**) FS = Full Scale

The differential sensor occupies two pressure outlets.

Note: Optional **BR (Barometric Reference – 1barA)**

Sensor for ambient pressure measurement. Can be used for simulated indication of absolute pressure in other sensors. Accuracy of ± 0.02 % FS (1 bar).

9

Pressure accuracy values are valid within one year and temperature range of 20 to 26 °C. Outside these limits add 0.005 % FS/ °C taking 23 °C as the reference temperature. These values are obtained through algorithms of temperature compensation on pressure measurements.

Probe

Probe is a high accuracy 4-wire Pt100 available under ordering. The calibrator input accepts Callendar-Van Dusen and ITS-90 curve correction coefficients

MPYA Pressure Module

Optional independent pressure measurement module. The MPYA communicates with the MCS-XV which performs pressure indication. See MPYA specifications on the Presys website.



1.5. General Specifications

RTD input for 2, 3 and 4 wires. Table IEC 60751, Callendar-Van Dusen, or ITS-90 user-configurable.

Regulated transmitter power supply (TPS): 24 Vdc, with protection for short circuit (30 mA).

Contact input for calibration of switches (pressure switch, thermos switch etc.).

50 Vdc in/out insulation.

Five minutes warm-up time.

Operating temperature range: 0 to 50 °C.

Relative Humidity: 0 to 90 % RH.

Pneumatic Connection: 1/4" NPTF (1/8" NPTF only for the range 0 – 10,000 psi or above).

Overpressure: up to twice the sensor full scale pressure (for sensors up to 5,000 psi).

Engineering units - Temperature: °C, °F, K.

Pressure psi, bar, mbar, MPa, kPa, hPa, Pa, atm, at, mmH₂O, mmH₂O@4°C, cmH₂O, cmH₂O@4°C, mH₂O, mH₂O@4°C, ftH₂O, ftH₂O@4°C, inH₂O, inH₂O@4°C, inH₂O@60°F, torr, mmHg, mmHg@0°C, cmHg, cmHg@0°C, inHg, inHg@0°C, inHg@60°F, gf/cm², kgf/cm², kgf/m² Built in Web Server, Ethernet communication. USB port or Wi-Fi (with optional adapter).

HART[®] Communication Protocol.

PROFIBUS[®] PA Communication Protocol (optional)

Calibration Certificate (optional).

One-year warranty, except for rechargeable battery.

Portable Version (MCS-XV). Designed for field-use



Rechargeable battery lasting up to 8 hours with current output in 12 mA and screen brightness set to 50%.

Included items: technical manual, USB x micro-USB cable, Ethernet cable, spare fuse, touchscreen pen, carrying case, power cable, battery charger and kit of test leads.

Dimensions: 140 mm x 250 mm x 80 mm (HxWxD).

Weight: 2,6 kg nominal.

Rack Mounting Version (MCS-XV-RM). Designed for mounting on 19" rack or workbench. Powered from 100 to 240 Vca, 50 / 60 Hz.

Included items: technical manual, USB cable (A/B), Ethernet cable, spare fuse, touchscreen pen, power cable and kit of test leads.

Dimensions: 132 mm x 483 mm x 250 mm (HxWxD).

Weight: 2,0 kg nominal.



Desktop Versions (MCS-XV-DT). Designed for use on workbench



Powered from 100 to 240 Vca, 50 / 60 Hz.

Included items: technical manual, USB cable (A/B), Ethernet cable, spare fuse, touchscreen pen, power cable and kit of test leads.

Dimensions: 132 mm x 308 mm x 275 mm (HxWxD).

Weight: 3,0 kg nominal.

NOTES:

- * MCS-XV e ISOPLAN[®] are Presys trademarks.
- * Presys reserves the right to amend this technical document without notice.
- * HART[®] is a Fieldcomm Group trademark.
- * Profibus[®] is a Profibus[®] International trademark.



1.6. Special Software Features

- Special functions:

- 1) **SCALE** : scales both input and output.
- 2) **CONV**: converts any input to any output, galvanically insulated.
- 3) **RAMP**: increasing or decreasing ramps with configurable travel times and landing.
- 4) **STEP**: steps or *setpoints* with configurable times.

- **Memory Manager**: Stores predefined configuration types by the user.

- **Automatic tasks**: creation of calibration service orders and automatic execution of calibrations, storage of the data obtained and issuance of reports and certificates.

- **Data Logger**: monitoring of input or output signals, storage, and visualization of data in chart or table.

- **Help Desk**: storage and viewing of videos and documents in the calibrator itself.

1.7. Order Code

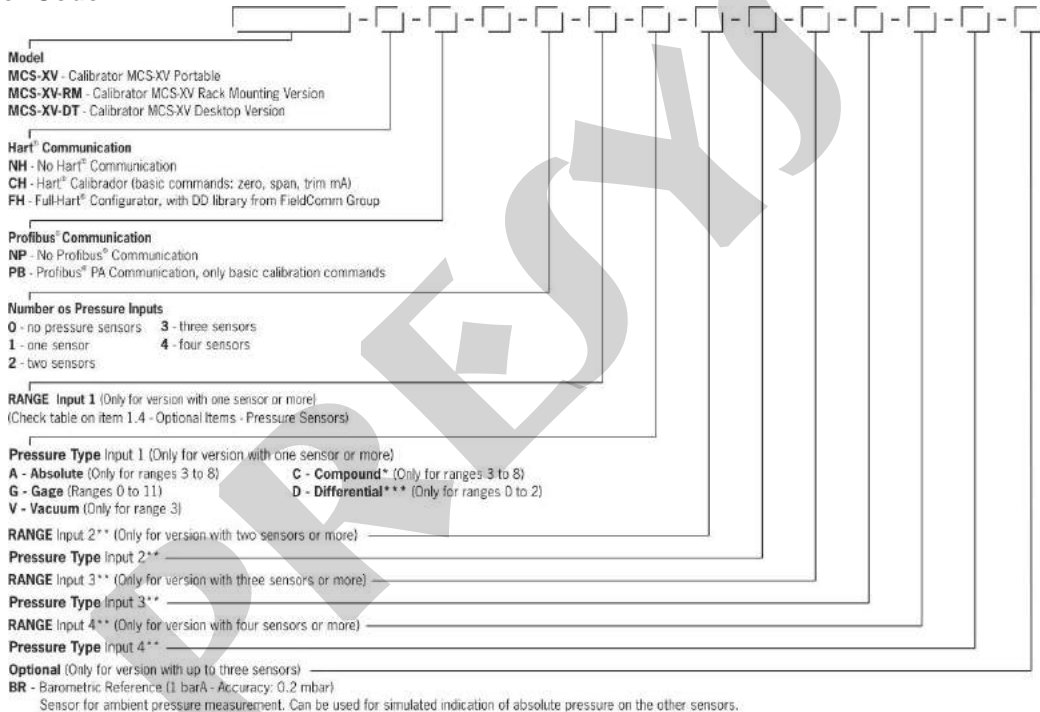

(*) From -1 bar to full scale of range (***) Same code as input 1. (***) The differential sensor occupies two pressure outlets.

2. OPERATION

2.1. Parts Identification

MCS-XV Portable

Front Panel

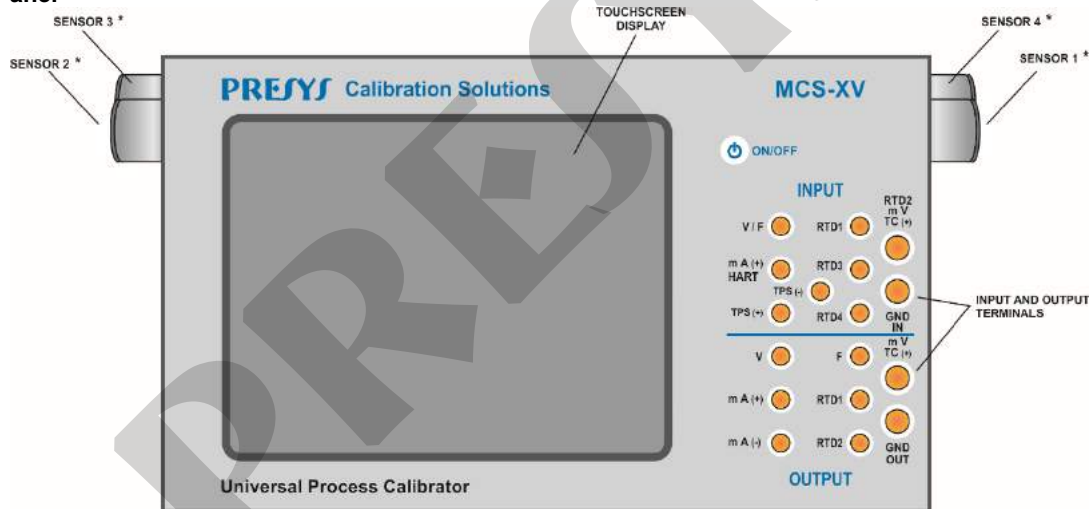

*Pressure sensors are optional items.

Fig. 01 – Front Panel – MCS-XV

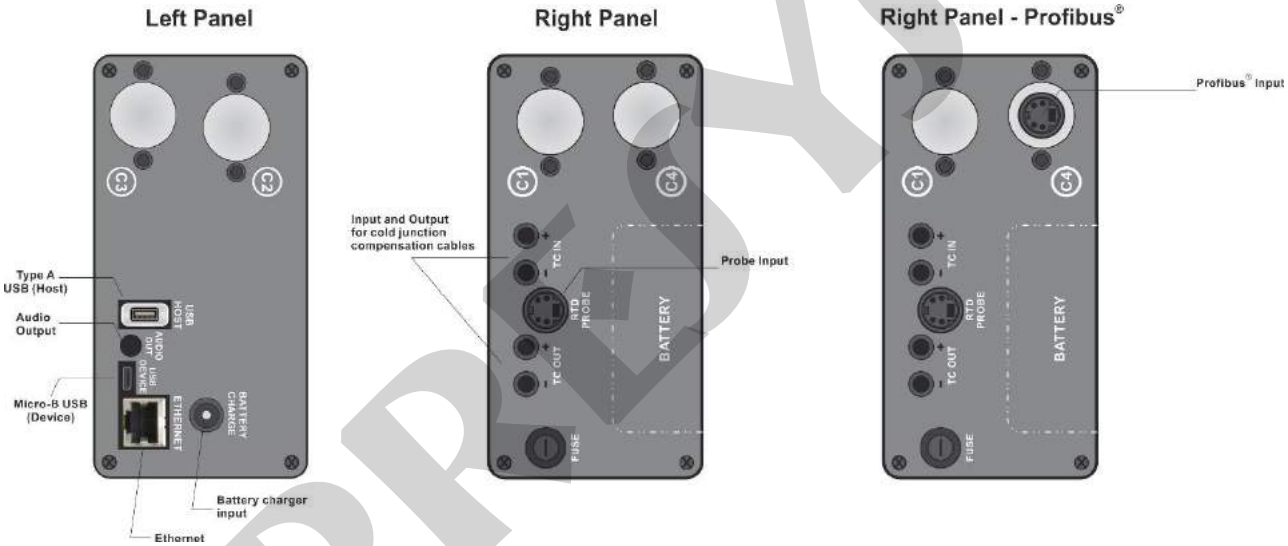

Fig. 02 – Side Panels – MCS-XV

Using the MCS-XV carrying case



Field use. Can be detached
for workbench use.

Fig. 03 – Using the carrying case

Included items: The case has three compartments: one to hold the calibrator and the others to hold various accessories including probe tips, adapter for connecting thermocouple wires, spare fuse, handles for carrying and field use, and a technical manual.

Optional: pressure capsules, the precision temperature sensor (**PROBE**), the pressure module (**MPYA**), the high precision external cold junction compensation block and the **ISOPLAN®** software are optional. The options are described in specific manuals.

MCS-XV-RM (Rack Mounting Version)

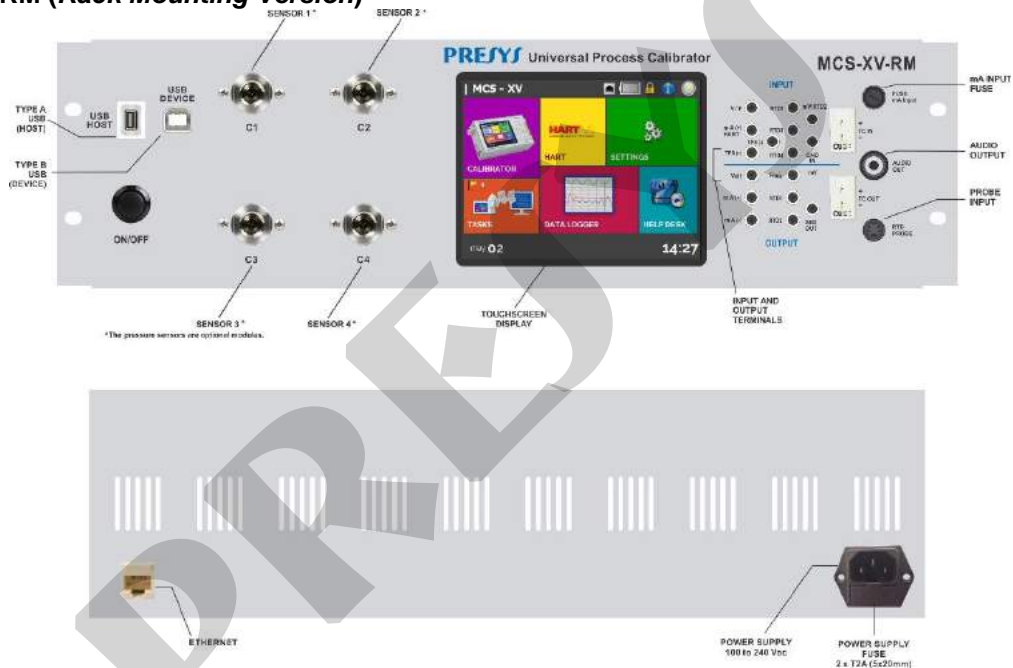

Fig. 04 – Front and back panels – MCS-XV-RM

MCS-XV-DT (Desktop Version)

19

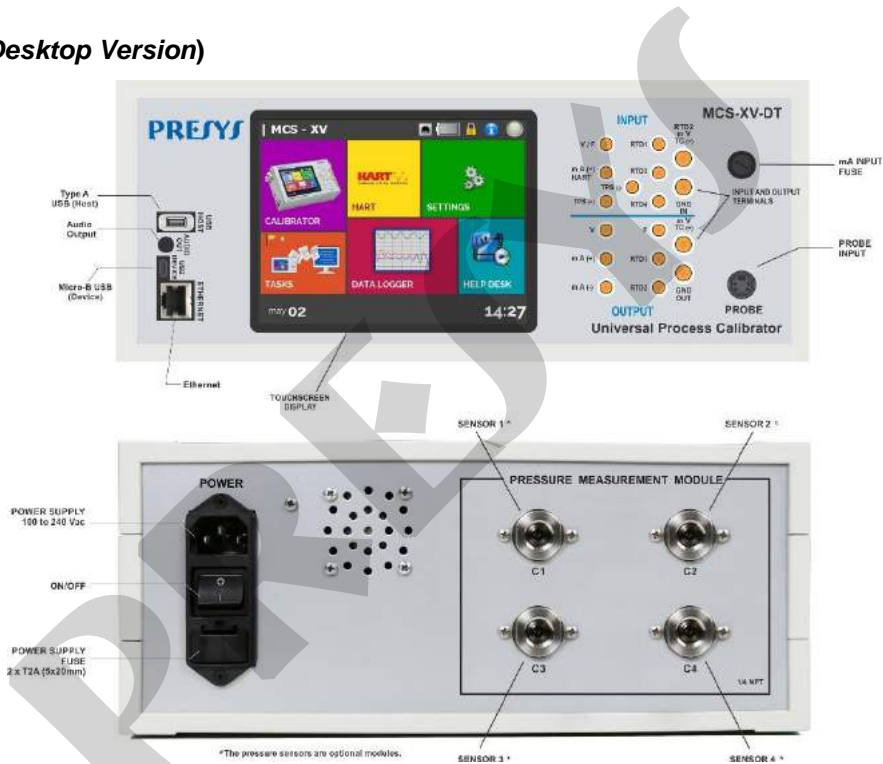

Fig. 05 - Front and back panels – MCS-XV-DT

2.2. Battery and Charger (only for MCS-XV Portable Version)

The MCS-XV is supplied with rechargeable battery which enables up to 10 hours of continuous use. This autonomy is reduced according to the active functions. A battery charger that can be plugged into power supply from 100 to 240 Vac is included. The time for full charge is 3 hours.

The battery level is displayed in the Main Menu, as shown below.

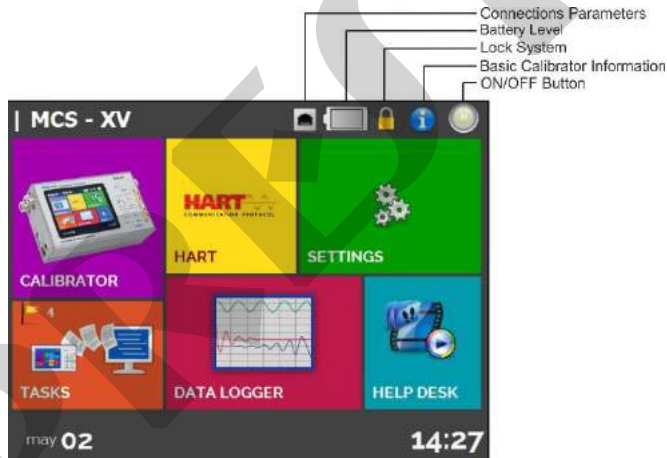

Fig. 06 – Main Menu

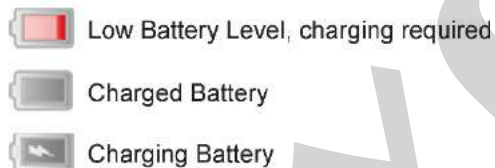

Fig. 07 – Battery level

Clicking on the battery icon, the following screen is shown. This screen shows the battery power (in percent), current (positive value if the battery is charging, negative if it is not) and the estimated time of instrument autonomy based on the current consumption.



Fig. 08 – Battery status

The charger provides the battery charge while it feeds the calibrator, thus permitting the calibrator to be used normally while the battery is being charged.

The batteries used by the calibrator are made of Lithium Polymer (Li-Po). This modern technology for rechargeable batteries does not have the undesirable characteristics of memory effect as their preceding batteries made of Nickel Cadmium (Ni-Cd).

To prevent explosion or fire, use only the battery charger supplied by Presys. Do not short circuit or damage the battery.

2.3. Using MCS-XV: Basic Functions

When powered on, the calibrator goes through a self-test routine and shows the last adjustment date. In case of failure, it displays a message to indicate error; if that occurs, the instrument should be sent to manufacturer for repair.

After the self-test is completed, the display shows the main menu, as showed in **Fig. 06**.

The main menu is divided into 06 (six) functions:

CALIBRATOR – selects the input/output functions, see section 2.4.

HART[®] – optional module that allows communication with devices that have Hart[®] protocol, see section 2.5.

SETTINGS – general instrument settings, see section 3.

TASKS – performs calibrations automatically, see section 2.7.

DATA LOGGER – record measurements, enabling visualization in chart or table, see section 2.6.

HELP DESK – features videos made by Presys to assist in the use of the calibrator and can also store videos and documents made by the user, see section 2.9.

2.4. Calibrator

To select the input or output functions, from the main menu, press the **CALIBRATOR** button. The following screen is displayed.



Fig. 09 – Calibrator Function

At the top is shown the Channel 1 and at the bottom the Channel 2. It can be changed in **Layout** option on Quick Navigator menu.

The icon  shows a **Quick Navigator**, with the options for Main Menu (**HOME**), **Data-Logger**, **Tasks**, and an option to enable the **CH-2** (Channel 2). Pressing **MORE OPTIONS** there are options for the selection of display

Layout, Memory Manager (see section 2.4.6), **AD/RATIO** (see section 2.4.7) and **BARGRAPH** (see section 2.4.8). Furthermore, it brings information about the input/output configuration and IP address. Press **BACK** to return to Calibrator Mode or **HOME** to go to Main Menu.



Fig. 10 – Quick Navigator and Secondary Menu

The Channel 1 can be configured only as an input. The Channel 2 can be configured as an output (default setting) or as **PROBE** or **PRESSURE** input. An example of Channel 2 used as input is the calibration of a pressure transmitter, when you want to measure the transmitter current (mA input on CH-1) and the pressure (PRESSURE input in CH-2).

To enable Channel 2 as input, press the icon  and enable the **CH-2** option. To enable Channel 2 as output, disable **CH-2** option. To return to the Calibrator screen press the **BACK** button. To go to the main menu, press the **HOME** button.

2.4.1. Measure or Input Functions

a) Input Type Configuration

Press **Input CH-1**, select through the menu the type of signal to be measured and use the corresponding terminals (see **Fig. 17 – Input Connections** or press the **HELP** button).



Fig. 11 – Input selection

For **OHM** measurement, select between 2, 3 or 4 wires options.

In **FREQ.** option, select the frequency or counter input.

For counter input must also set the time (in seconds). If time is zero, there is a continuous count of pulses received at the input. If the value is not zero, the count is done only during this time (window). The count starts immediately after pressing the **OK** button.

For **RTD** input, choose the standard table type used, the number of lead wires (2, 3 or 4 wires) and the temperature scale (ITS-90 or IPTS-68).

You can also set the Callendar-Van Dusen or ITS-90 sensor coefficients by selecting the CVD or ITS-90 option and the desired curve from the ID list. To create new CVD or ITS-90 coefficients or edit existing ones, select between the two options, and press the edit button  and then, the button **ADD**. The curves created appear in the list ordered by the **ID**. Select **CONFIGURATION** to enter an ID or tag for the sensor in **ID** and inform the sensor range in **MIN** and **MAX**. Select **PARAMETERS** to enter the sensor curve, usually informed on the sensor calibration certificate.

For Callendar-Van Dusen

Fill in the value of R_0 (Resistance to 0 °C) and parameters A, B and C together with their exponents.

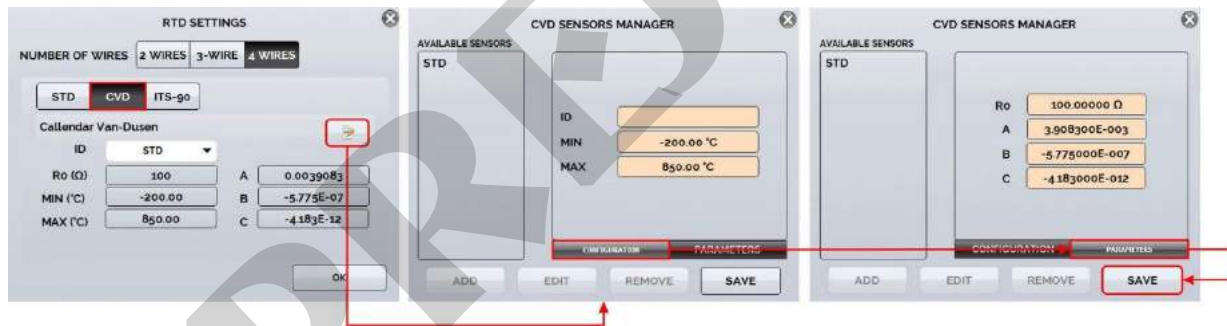

Fig. 12 - Callendar-Van Dusen Coefficient Configuration

For ITS-90

Fill in the value of RPTW (Resistance at 0.01 °C) and select the range for negative and / or positive curve before entering the parameters together with their exponents.

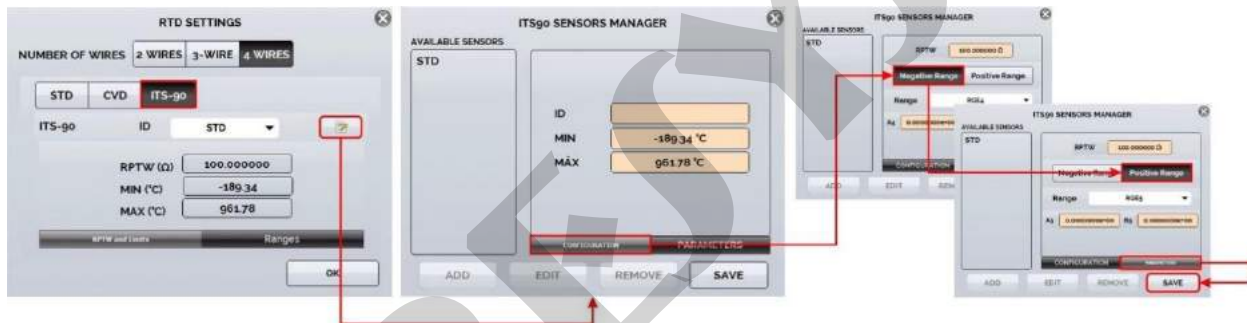

Fig. 13 - ITS-90 Coefficient Configuration

Negative Range: Accesses the coefficients to be used for temperatures below or equal to the triple point of water (0.01 °C).

Recommended Temperature Range (Negative)		Coefficients
Range 4	-189.3442 °C to 0.01 °C	A4, B4
Range 5	-38.8344 °C to 0.01 °C	A5, B5

Positive Range: Accesses the coefficients to be used for temperatures above the triple point of water (0.01 °C).

Recommended Temperature Range (Positive)		Coefficients
Range 6	0.01 °C to 961.78 °C	A6, B6, C6, D6
Range 7	0.01 °C to 660.323 °C	A7, B7, C7
Range 8	0.01 °C to 419.527 °C	A8, B8
Range 9	0.01 °C to 231.928 °C	A9, B9
Range 10	0.01 °C to 156.5985 °C	A10
Range 11	0.01 °C to 29.7646 °C	A11
Range 5	0.01 °C to 29.7646 °C	A5, B5

A, B, C, D: ITS-90 coefficients

Note that the POSITIVE and NEGATIVE groups include a common range: **Range 5**. If you need to use their coefficients for the positive and negative ranges, set the coefficients equally for the positive and negative ranges. The coefficient values can be found in the reference sensor certificate.

After filling in the blanks, click the **SAVE** button and confirm. The new sensor is now available to be chosen from the list. To edit data from a sensor, select it and press the **EDIT**  button. To remove a sensor, select it and press **REMOVE**.

PROBE refers to temperature measurement with an optional 4-wires Pt-100. Using Probe, it is possible to measure temperatures from -200.00 °C to 850.00 °C with high accuracy. There is also the option to configure the Sensor's Callendar-Van Dusen or ITS-90 coefficients, which follows the same procedure as the RTD input sensors, reported above.

For **TC** (thermocouple) input, select the thermocouple type and the type of cold junction compensation (CJC): **Internal**, **Manual** or **Probe**.

In the **Internal option**, compensation is performed by a sensor installed internally in the calibrator.

In **Manual**, set the value of the cold junction temperature to the calibrator.



The **Probe** option corresponds to measuring the cold junction through a probe sensor or the external cold junction compensation block of high accuracy. One can use this block to accurately measure the cold junction of both input and output thermocouple. Connection details can be found in item **e)** of this same section

It is possible also enter thermocouple curves as well as RTD curves. Select **CUSTOM** and choose one of the registered thermocouples from the list. To enter or edit data from a sensor, press the edit button  and save or change the parameters of the sensors.

The **PRESSURE** option corresponds to the inputs that allow pressure measurement by using pressure sensors installed on the sides of the calibrator (if requested). After pressing the **PRESS** button, select the capsule to be read (C1, C2, C3 or C4).



IMPORTANT: If the calibrator was purchased with the Profibus[®] PA module, the input reserved for the C4 pressure sensor will not be available and is reserved for the Profibus connector[®].

Optional BR - to use the Barometric capsule to indicate the pressure of any other pressure sensor in Absolute mode, use Channel 2 (enable Channel 2 by pressing the button and then  → **CH-2**). Select the pressure sensor to use, click the gear icon and press  **ABS**.

MPYA module - To use it, connect the MPYA to the USB port of the calibrator using the TTL/USB cable that came with it. Then press the **PRESS** button and then the desired sensor. The calibrator will start reading the pressure immediately thereafter.

The **SWITCH** input is a measurement of continuity of an external contact connected to the input (between RTD1 and RTD4) of MCS-XV. When there is continuity, the input shows **CLOSED**, otherwise it shows **OPEN**.

b) Pressure Switch Test

By pre-selecting, the pressure indication on Channel 2, in **SWITCH** the automatic pressure test function is enabled. In this function it is possible to check the contact opening and closing values of pressure switches. This requires a pressure source that varies at a slower ramp for greater accuracy. For these tests, it is recommended to increase the read rate of the A/D to **FAST** converter. See more information in section **2.4.7 - A/D RATIO**.

Select **SWITCH** then **PRESSURE SWITCH TEST**. The following screen is shown. Fill in the pressure switch identification fields and values for **TRIP** (value for closing/ opening of the pressure switch relay), **DEAD ZONE** (pressure hysteresis value) and **TRIP ERROR / DEAD ZONE ERROR** (tolerance values for trip and zone error dead for PASS/FAIL of pressure switch). For test reporting, use the **TASKS** function.

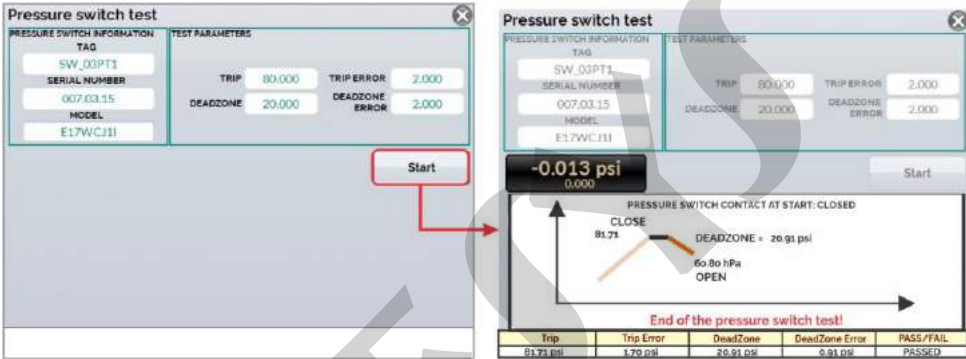

Fig. 14 – Pressure Switch Test

c) Burn-Out Warning

When the input sensor breaking occur (RTD, resistance or probe) the display shows the burn-out warning identified by question marks illustrated below:



Fig. 15 – Burn-out warning

Whenever the input signal is above or below the input ranges established in Section **1.2 Specifications-Input**, the display indicates **OVER** or **UNDER**, respectively.

d) Engineering Units Change

The units of temperature and pressure can be changed by clicking on the engineering unit (°C, °F, psi, atm etc.) and selecting the desired option.

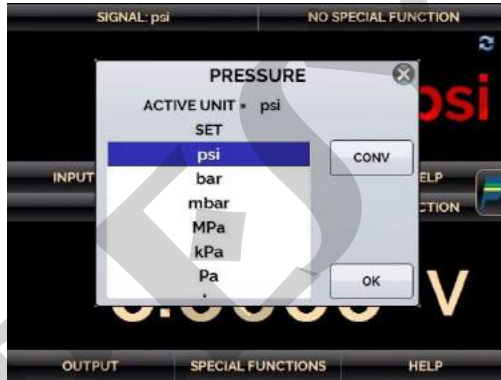
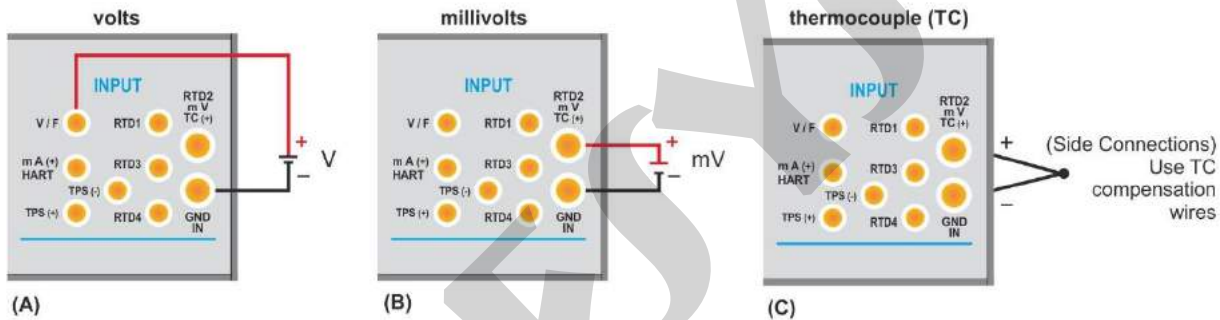

Fig. 16 – Engineering Unit Selection

e) Input or Measurement Connections



Note: For RM version, use standard thermocouple sockets as shown.

Note: For FS and DT version, connect the TC wires into the terminal screws, according to the figure above.

Fig. 17 – Input Connections

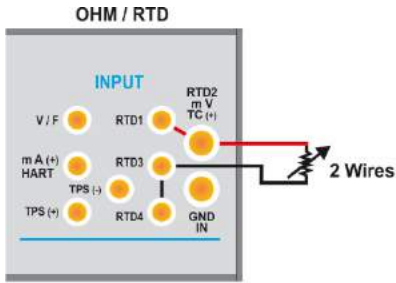

(D)

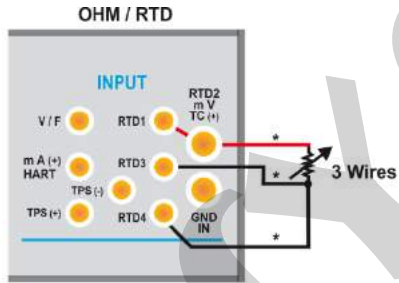

(E) * Use wires with the same length and gauge.

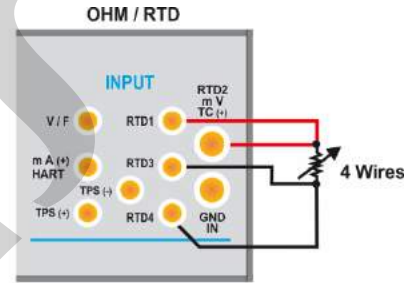

(F)

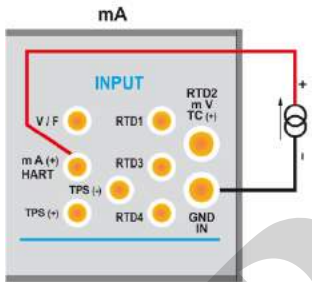

(G)

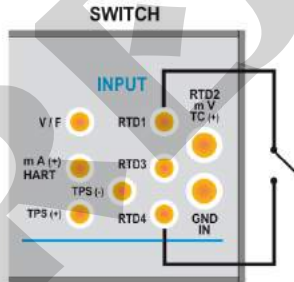

(H)

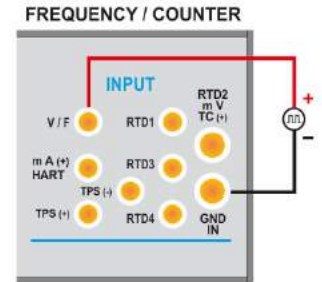

(I)

Fig. 17 - (Cont.) Input Connections

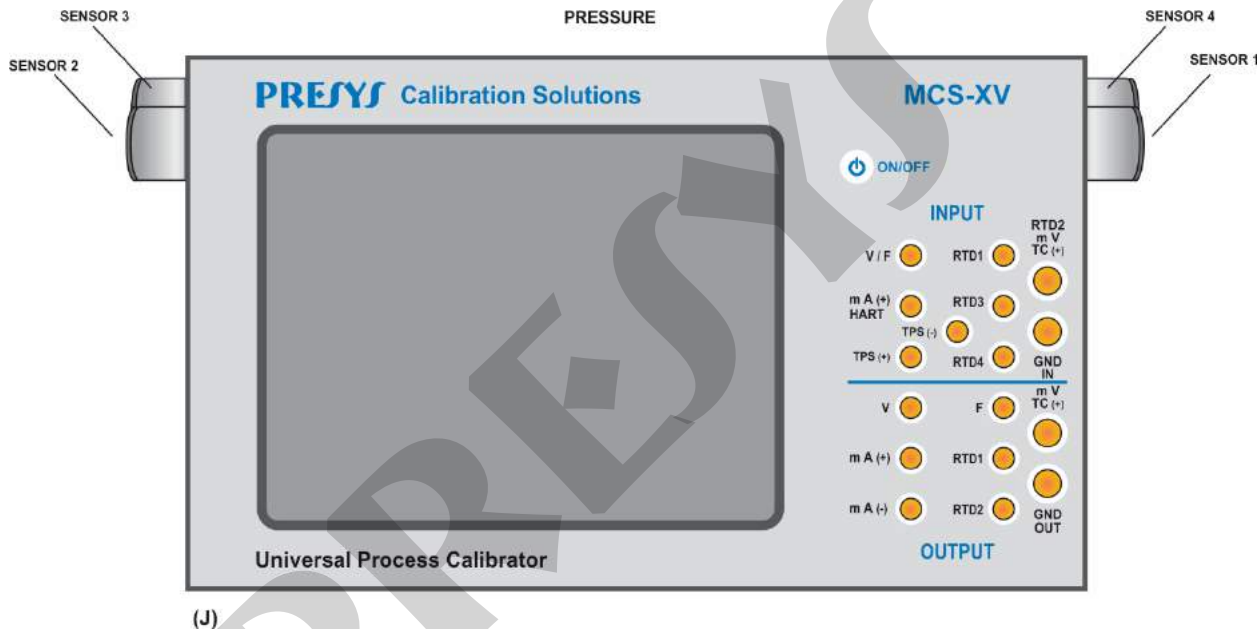

Fig. 17 - (Cont.) Input Connections



NOTE: For versions RM and DT, check the position of the pressure sensors in **Fig. 04** and **Fig. 05**, respectively.

f) Probe Connection (optional)

Connect the **PROBE** to MCS-XV so that the polarity identifications match. See figure below.

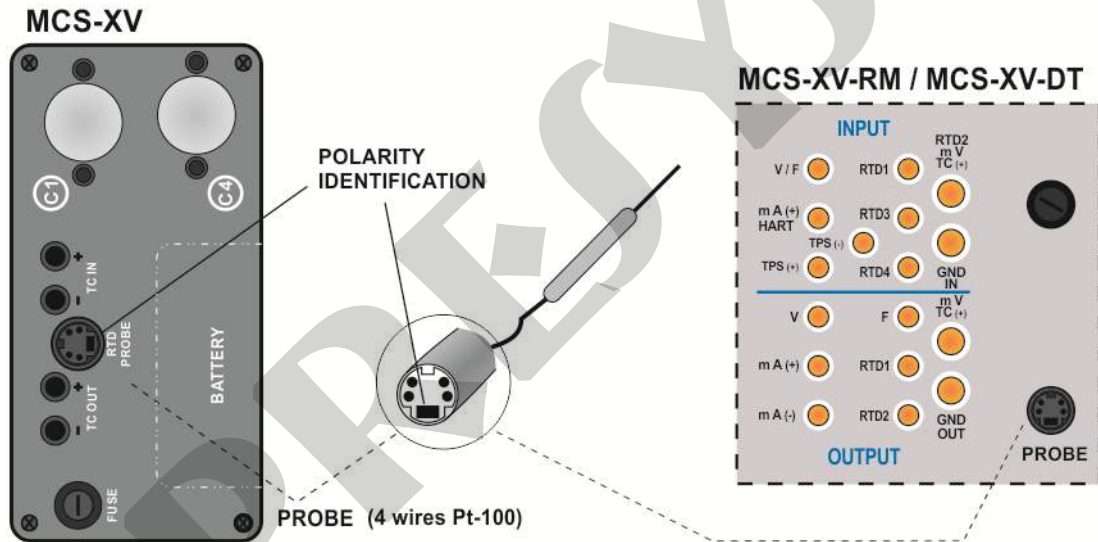

Fig. 18 – Probe Connection

g) High Accuracy External Cold Junction Compensation Block Connection – CJCB (optional)

38

Insert the high precision block in the TC input (IN) or TC output (OUT) terminals and connect the cable which comes out of the block to calibrator Probe connector according to the same polarity described in item f) above. Depending on the block insertion in the TC input or in the TC output, the thermocouple connection will have its input or output cold junction given by the external compensation block. The input or output thermocouple connection must be made in the external compensation block itself. See the following figures:

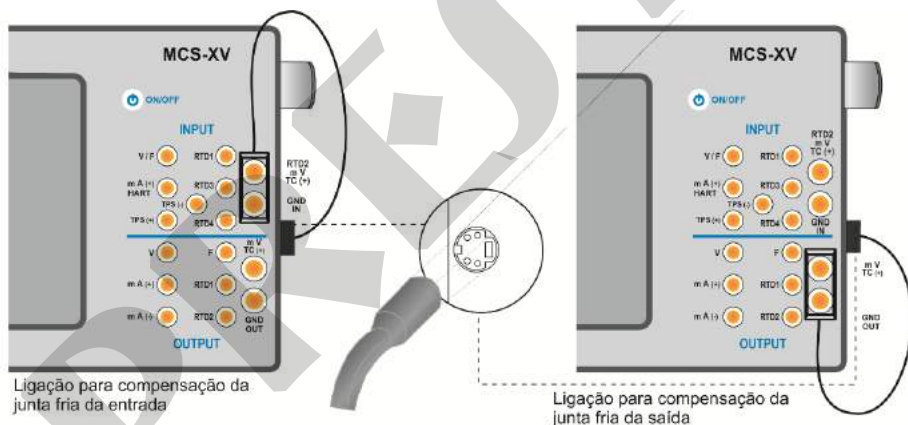

Fig. 19 – CJCB Connection

For an effective input or output cold junction measurement with the block, the **PROBE** option of thermocouple cold junction must be selected and enabled. In **CJC TYPE** select **PROBE**.

h) Profibus® Connection

To use the input for calibrating instruments with Profibus® communication, insert the communication cable into the respective calibrator input and connect the test leads to the device to be calibrated (see **Fig. 56** and **Fig. 57** for reference).

2.4.2. Generation or Output Functions

a) Output Type Configuration

Press the **OUTPUT** button, select through the menu the type of signal to be generated and use the corresponding terminals (see **Fig. 22 - Output Connections** or press the **HELP** button).



Fig. 20 – Output Type Selection





The **FREQ.** option allows the selection of the frequency or pulse generation. For the frequency generation, it must be chosen between the bands of 100 Hz or 10000 Hz. It can also be adjusted the amplitude, which varies from 0 to 22 V. For the pulse generation (square wave) in addition to the amplitude and the number of pulses, one must provide the rate at which the pulses should be sent, given in Hz. The pulse sequence is sent as soon as **OK** is pressed.

For the **RTD** or **OHM** generation, the calibrator simulates electronically a resistance value, i.e., there is no resistor but an electronic circuit which behaves as a resistor. It was designed specifically with the purpose of simulating RTD so that the calibrator can be connected to instruments such as indicators, transmitters, temperature controllers, with an excitation current within the range of 150 μ A to 5 mA. For **OHM** generation, you should choose between the range of 400 Ω and 2,500 Ω .

TC (Thermocouple): To perform the thermocouple sensor simulation, select the TC output and, on the following screen, set the Standard Table and the type of cold joint (CJC). After parameterizing the output, press the OK button.



NOTE: For both RTD and TC outputs it is possible to configure correction curve coefficients (see item **2.4.1 a) Input Type Configuration** to configure the curves).

To change the value of the output, press on the number and type the desired value on the keyboard. Another way to change the output value is to modify each digit separately in fixed steps. To do this, hold the output value for at least 3 seconds, choose the digit to be changed (the selected digit is indicated with arrows  and ) and press the buttons  and  to change the setpoint.

To exit this edit mode, hold down the output value for at least 3 seconds

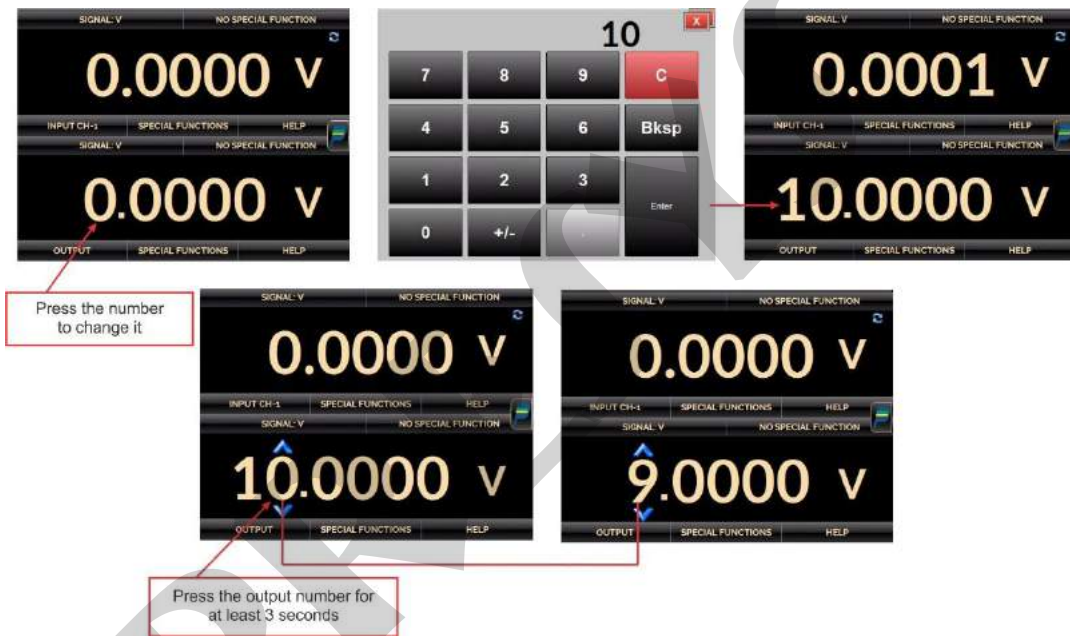
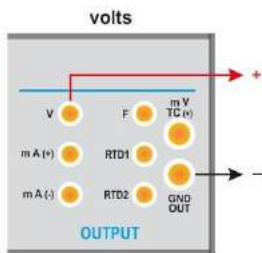

Fig. 21 – Changing the Output Value

The temperature units can be changed by clicking on the unit and selecting the desired option. The **NONE** option disables the output function.

b) Output or Generation Connections



(A)

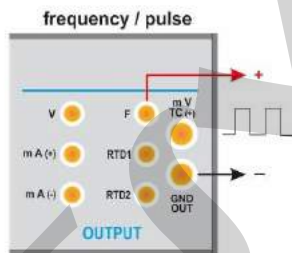

(B)

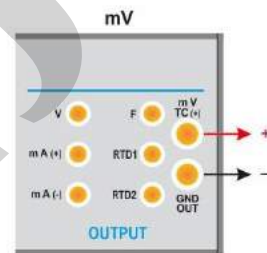

(C)

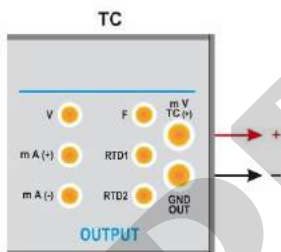

(D)

(Side connection)
Use TC compensation wires

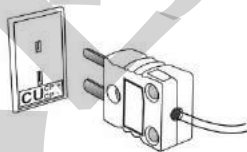

Note: For RM version, use standard thermocouple sockets as shown.

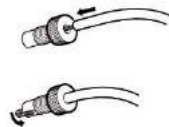

Note: For FS and DT version, connect the TC wires into the terminal screws, according to the figure above.

Fig. 22 – Output Connections
mA (passive mode)

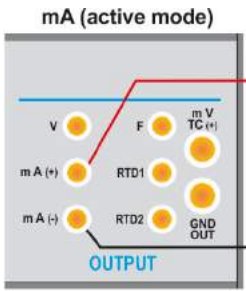

(E)

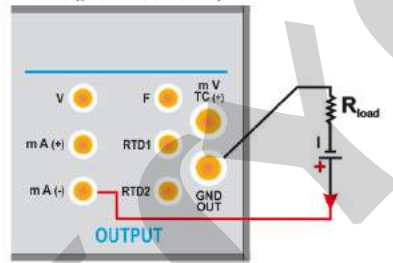

(F)

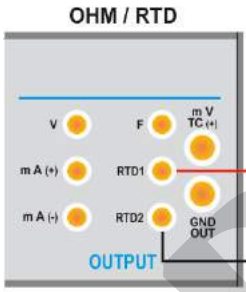

(G)

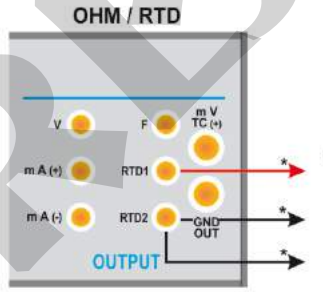

(H) (*) Use same gauge and length wires

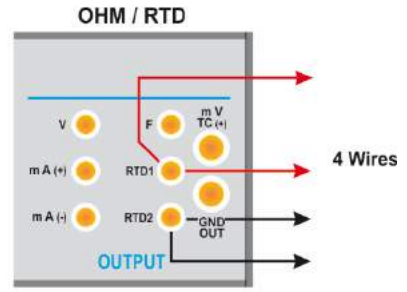

(I)

NOTE: There is no polarity for resistance output.

Fig. 22 - (Cont.) Output Connections

PRESTYS

2.4.3. Available Power Supplies

The MCS-XV has two power supplies galvanically isolated: TPS and +22.5 Vdc at the output, both provided with short-circuit protection (current limited to 30 mA).

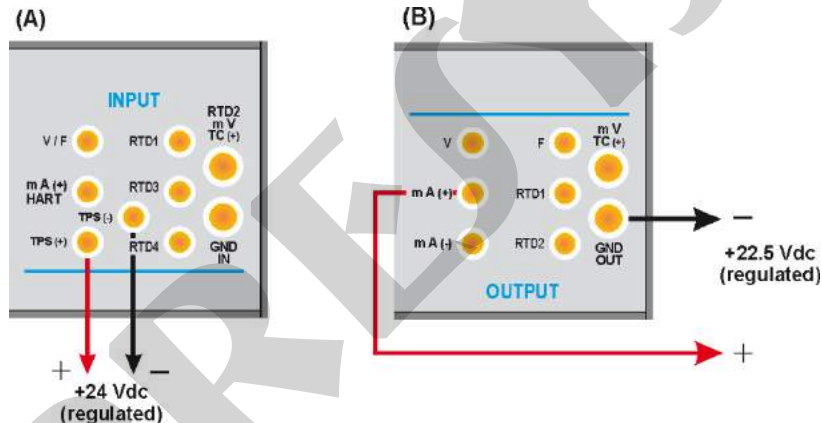

Fig. 23 – Power Supplies

2.4.4. Input Special Functions

Selecting **SPECIAL FUNCTIONS** in the input channel, the display shows the following pop-up:

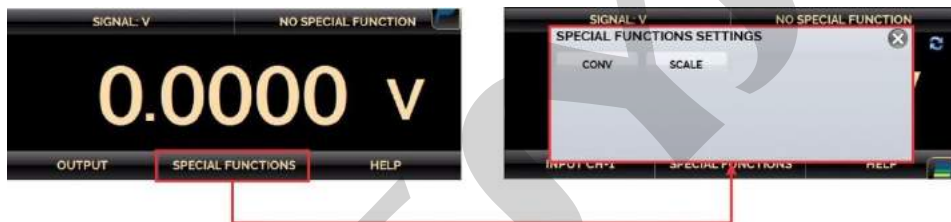

Fig. 24 – Input Special Functions

The selected special function will act on the previously selected input.

After selecting and configuring the special function, to enable it change to on the key status ON and confirm in **OK**. To disable it change the key to OFF. To change the state of the key, just click on it.

When there is no active special function, the screen displays the message **NO SPECIAL FUNCTION** at the top.

a) SCALE Function

It establishes a linear relationship between the MCS-XV input signal and what is shown at the display, according to the graphic below:

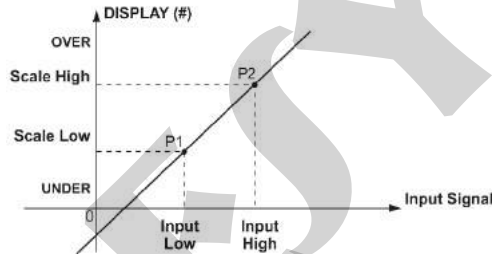

Fig. 25 – SCALE Function (LINEAR)

The image shown below presents the SCALE FUNCTION configuration menu.



Fig. 26 – Scale Function Configuration

The scaled indication at the display (#) may be changed to represent any engineering unit, such as: m/s, m³/s, % etc. The number of decimals, up to 4, shown at the display may be configured.

The value for **Input High** must be necessarily higher than **Input Low**. On the other hand, **Scale High** and **Scale Low** may have any relationship between themselves: higher than, lower than or equal to, and they may have a signal before them. Thus, direct, or reverse relationships may be established.

The counter and the contact inputs cannot be scaled.

For the current input, a linear relationship may be established as it has been previously shown or it may be squared (**FLOW**) as illustrated below:

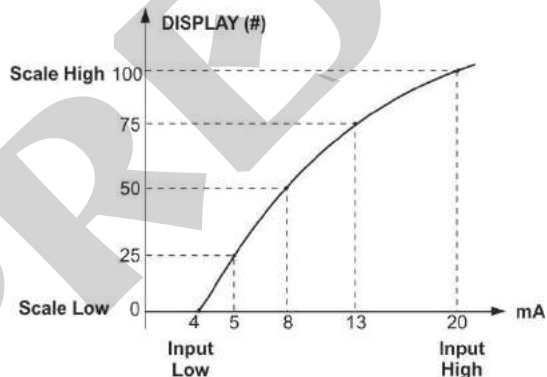

Fig. 27 – SCALE Function (QUAD)

b) CONV Function

By using the **CONV** function, the calibrator may convert any input signal into any output signal with galvanic isolation. It may, therefore, behave as a real transmitter.

Once the calibrator input and output have been selected, fill in the four parameters shown in the graphic below:

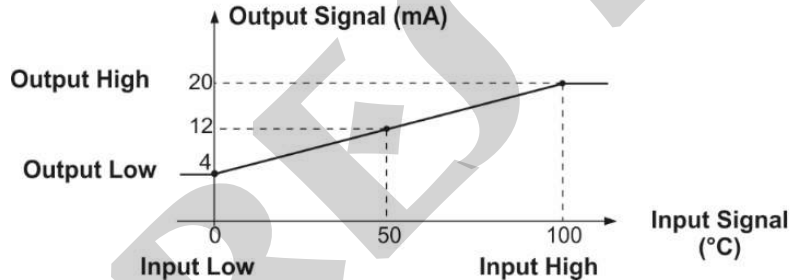

Fig. 28 – CONV Function

The value of **Output High** must always be higher than **Output Low**. **Input High** and **Input Low** parameters must never be equal. Thus, any type of direct or reverse retransmission, from input to output, can be obtained.

The image shown below presents the CONV Function configuration menu.

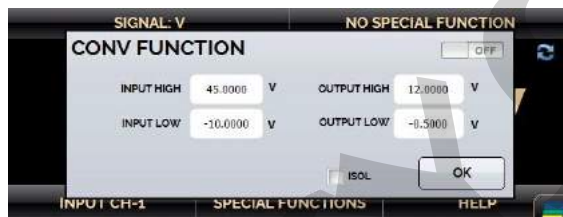

Fig. 29 – CONV Function Configurations

2.4.5. Output Special Functions

Selecting **SPECIAL FUNCTIONS** in the output channel, the display will show:

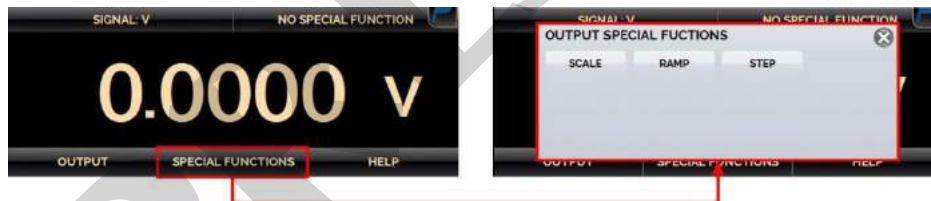

Fig. 30 – Output Special Functions

The selected special function will act on the previously selected output.



After selecting and configuring the special function, to enable it change to on the key status ON and confirm in **OK**. To disable it change the key to OFF. To change the state of the key, just click on it.

When there is no active special function, the screen displays the message **NO SPECIAL FUNCTION** at the top.

a) RAMP Function

By using this programming, the MCS-XV output varies automatically, producing ramps and level marks which may be programmed to actuate once or continuously.

To access the **RAMP** mode configuration menu, select the function after pressing the **SPECIAL FUNCTIONS** button. On the next screen, set the maximum (**MAX**) and minimum (**MIN**) values desired for the output execution range. Then set the landing duration time (**WAIT**) in seconds, that is, the time that the output should remain constant between two ramps.

After configuring the RAMP function and enable it (change the key status to , press the **OK** button. To start the ramp, press the chronometer icon . The ramp runs continuously according to the defined strategy (up, down, up/down). To stop, press .

The image shown below presents the RAMP configuration menu.



Fig. 31 – RAMP Function

b) STEP Programming

The **STEP** programming makes the calibrator output vary in pre-defined steps. It is useful in calibrations where some scale points are verified, for example: 0% - 25% - 50% - 75% - 100%.

To generate setpoints, you must set the minimum and maximum range points (**MIN** and **MAX**), the output percentage change for each step (%) and generate the list (📄 button). There is also the option to manually add or delete any point to the list of setpoint values (⊕ button: adds a point to the list, ⊗ button deletes the selected point, ✖ button deletes all points).

If you want each step is achieved automatically after a preset time, you must set the **TIME** in seconds. In this situation the steps are generated automatically and continuously. Activating the function and pressing **OK**, the output starts executing the **STEP** program, always starting from the beginning of the range. To move to the next step, you

must press \uparrow . Pressing \downarrow it goes to the previous step. Pressing \odot , the steps are automatically and continuously generated according to the set time. To stop, press .

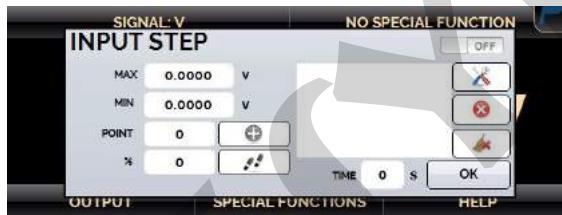

Fig. 32 – STEP Function

c) SCALE Function

The scaling of the output from MCS-XV allows it to simulate the operation of a transmitter. In this case, the display scaled indication (#) simulates the transmitter input (which can be changed by pressing the number indicated on the display and entering the desired value), and as output signal it can have any of the signals generated by the MCS-XV (e.g., 4 to 20 mA).

SCALE output function relates the output signal generated by the MCS-XV with what is shown on the display as the example shown below.

The scaled indication at the display (#) may be changed to represent any engineering unit, such as: m/s, m^3/s , % etc.

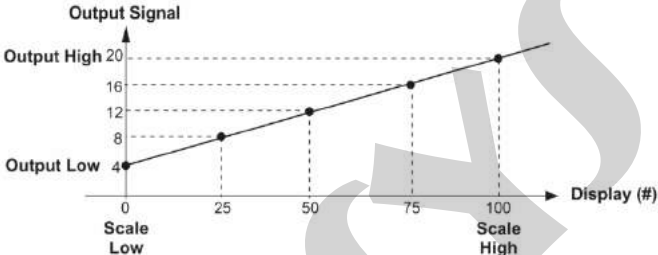

Fig. 33 – SCALE Function (LINEAR)

The number of decimals, up to 4, shown at the display may be configured.

The value for **Input High** must be necessarily higher than **Input Low**. On the other hand, **Scale High** and **Scale Low** may have any relationship between themselves, if they are not equal. Thus, direct, or reverse relationships may be established.

Any type of output can be scaled, except the pulse output.

For the current output, a linear relationship may be established as it has been previously shown or it may be squared (**FLOW**) as illustrated below:

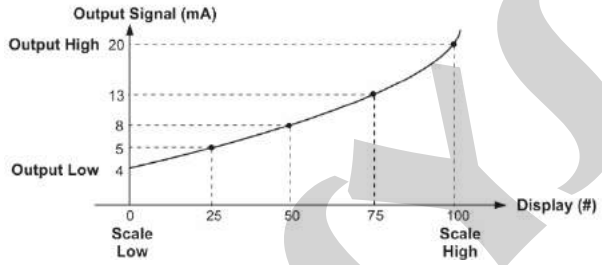



Fig. 34 – SCALE Function (FLOW)

2.4.6. Saving Current Configuration (Memory Manager)

The MCS-XV admits several special functions that can be used frequently, and it is useful to store settings on the instrument to save time.

After setting the desired mode (input type, output type, special functions), press the  → **MORE OPTIONS** icon, and the **MEMORY MANAGER** button. On the bottom of the screen, type the name for this configuration and a description. Press the **SAVE** button to store the added information.

The operation that was being performed by the MCS-XV shall be stored in memory identified by the name given to it. To use it again, even after turning the calibrator off and on, enter the **MEMORY MANAGER** option and select the name of the desired setting and press the **LOAD** button.

The **SAVE AS DEFAULT** button sets the current calibrator setting to the default *setting*. That way, every time the MCS-XV is turned on, this will be the calibrator’s initial configuration.

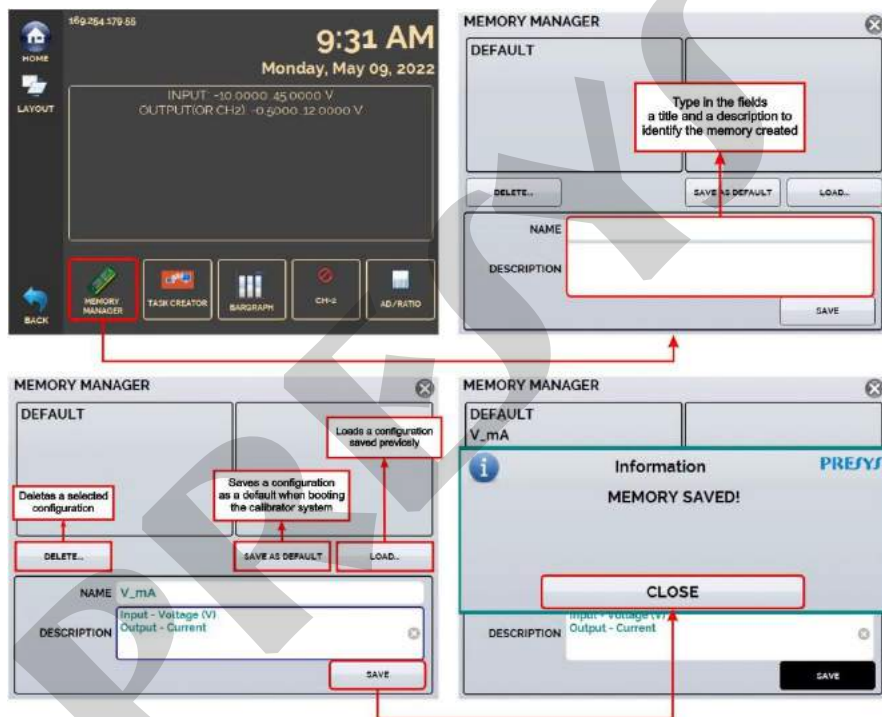

Fig. 35 – Memory Manager

2.4.7. AD/Ratio

The MCS-XV allows to change the conversion rate of the Analog/Digital Converter. With faster rates, the readings indicated in meter mode are updated more frequently, and with slower rates, the calibrator performs more readings and updates the values at a lower frequency.

For tests where reading speed is important, such as in tests of Pressure Switches and Thermostats, it is recommended to use a faster rate, which can "capture" the nearest value of opening/closing of kings. For calibrations and other tests, it is recommended to use a slower conversion rate, which provides more accurate readings.

To change the conversion rate, press the button  → **MORE OPTIONS**, and the **AD/RATIO** button. Select between **FAST**, **MEDIUM**, and **SLOW**.





Fig. 36 - A/D Converter

2.4.8. Bargraph

The MCS-XV allows to monitor an input and include HIGH and LOW alarms for the range.

To set up the alarm, press the button  → **MORE OPTIONS**, and the **BARGRAPH** button. Select from high and/or low alarms. Press **SOUND** to activate the calibrator beep when in alarm. In **EVENTS** you can check a list of times when the alarm detects values outside the registered tolerance.

Press the icon  to return to the Calibrator menu, keeping the monitoring bar next to it.

By pressing the icon , a screen for stability/leak testing is displayed. Select the time in seconds and click **START** to run the test. Choose which unit the results will be displayed in engineering unit for seconds (S), minutes (M), or hours (H). To use this feature, be sure to pre-configure the calibrator input for pressure reading.

During testing, you can increase the test time by pressing the +20s button. The S, M, and H buttons change the time unit in seconds, minutes, and hours, respectively. The display shows the signal variation between the first and last reading (Δv , in input unit) and the increasing and decreasing rate is calculated (average, in input unit / unit of time).



Fig. 37 – Bargraph Function

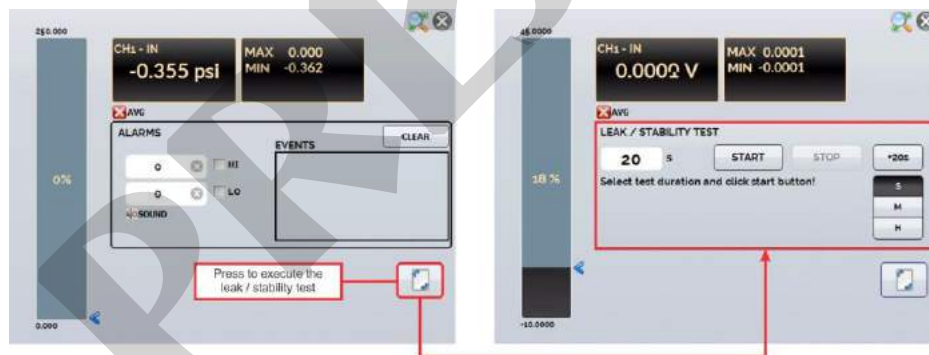

Fig. 38 – Stability Test

2.4.9. Calibration Examples

60

a) Temperature Transmitter Calibration (RTD Input and 4-20 mA Output)

Through the menus, you can configure the MCS-XV for mA input and output in RTD. The TPS (Transmitter Power Supply) is a source of 24 Vdc that provides power to the transmitter.

In the example, the connection of the RTD is made using three wires and being simulated by the MCS-XV. With this form of connection, there is no measurement error due to the resistance of the wires since these have the same length and gauge.

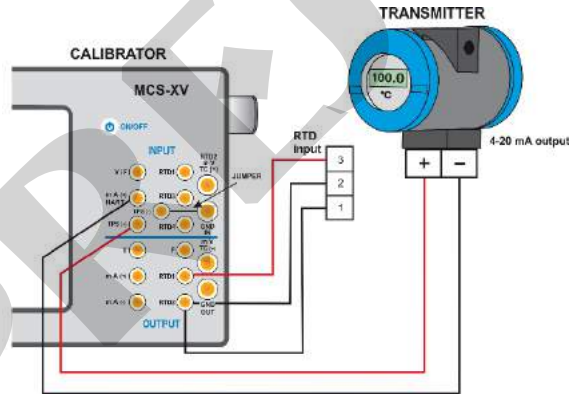

Fig. 39 - Calibration of a Temperature Transmitter 3-wire RTD Input

b) Temperature Transmitter 4-wired Calibration (110/220 Vac Power Supply – Thermocouple Input and 1-5 Vdc Output)

61

Setup the MCS-XV as volts output and TC input and select the **TC** type. For the cold junction compensation, you can use compensating wires TC to connect the transmitter to the MCS-XV and choose the option of **Internal** cold junction compensation, or you can measure the temperature of the terminal of the transmitter and enter this value in the **Manual** option in the MCS-XV, thus eliminating the use of compensating wires.

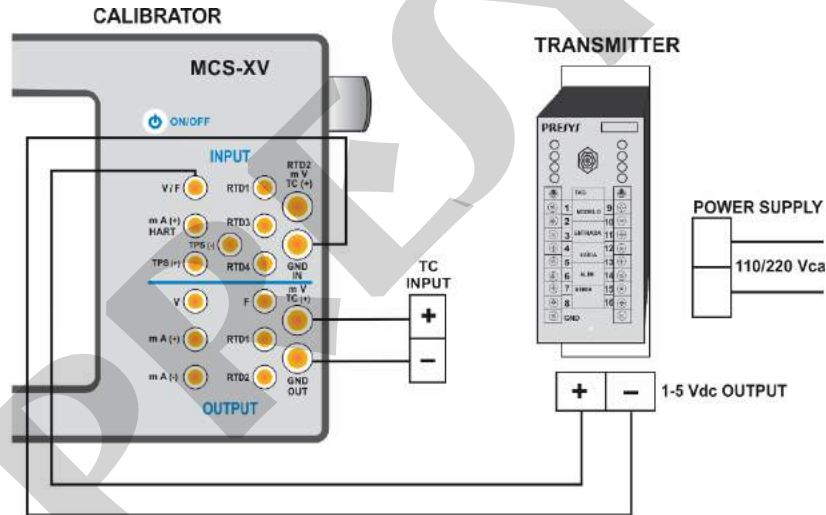

Fig. 40 – Calibration of a Temperature Transmitter (Thermocouple Input and 1-5 Vdc Output)

c) Pressure Transmitter Calibration

Use **TPS** MCS-XV source to power the two-wire transmitter 24 Vdc and connect the current as illustrated below. Select **mA** (current) in the Input menu of the CH-1 and **Pressure** Input on CH-2 menu.

To enable Channel 2 as input, press the icon  and enable the **CH-2** option. To return to the Calibrator screen press the **BACK** button.

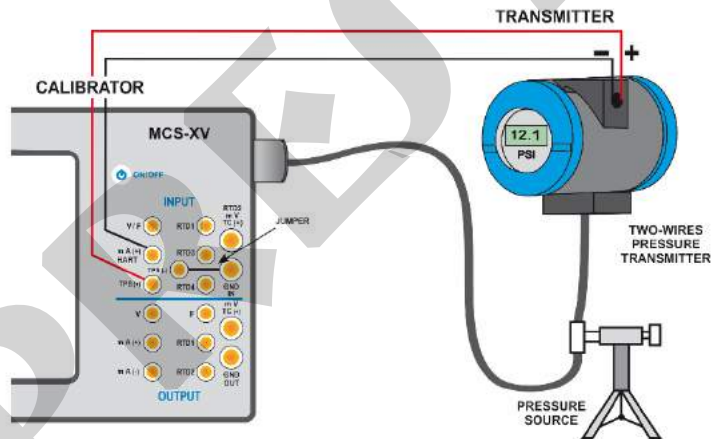

Fig. 41 – Pressure Transmitter Calibration

Current input readings can be scaled to pressure through the **SCALE** option. In this way the error between the input and output of the pressure transmitter is easily calculated.

d) Pressure Switch Verification

Pressure switches are devices that receive a pressure signal and have relay alarm. The relay is activated whenever the pressure passes above or below a certain setpoint alarm.

Connect the pressure switch output to the switch input of MCS-XV, **RTD1** and **RTD4** terminals, and make the pneumatic connections as illustrated in the figure below:

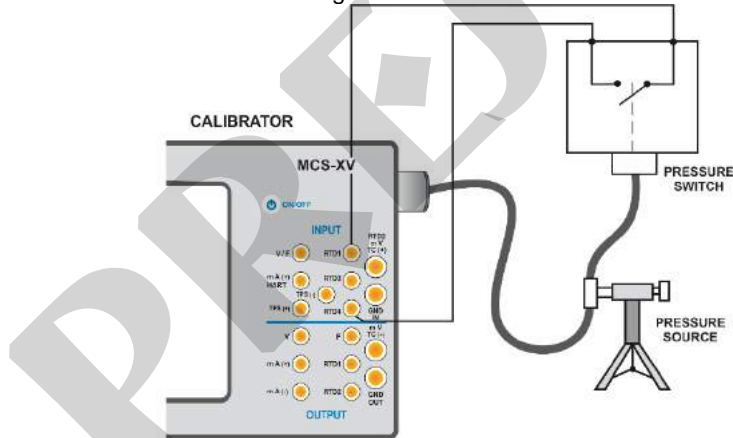

Fig. 42 – Pressure Switch Verification

Channel 2 must be enabled and selected **PRESSURE**. You must select the corresponding sensor. On Channel 1, select **SWITCH** input and enter **PRESSURE SWITCH TEST**.

The MCS-XV shows the pressure measurement and the contact status (**OPEN** or **CLOSED**).

Press **RUN** to start the test after filling in all required fields.

Vary the pressure manually or with the help of an automatic pressure controller. The instant the relay changes position, it is shown on the display the alarm setpoint pressure switch, so the change from open to closed or from closed to open.

2.5. HART®

Isocal MCS-XV can be used to read and configure instrument parameters that have HART® Communication Protocol. The HART® protocol allows digital communication between the master (in this case, the MCS-XV calibrator) and the slave (field instrument) overlaps with the analog signal from 4 to 20 mA. To access this function, from the main menu, select the HART® option.

Hart® communication of the MCS-XV Isocal calibrator is an optional module. The calibrator has three versions: **NH** (without HART® communication), **CH** (HART® calibrator) and **FH** (Full-HART® configurator, with DD library).

The **CH option** has basic and universal commands for HART® communication (zero, span, trim mA...), which allow instrument range adjustment, primary variable monitoring, current adjustment, etc. The **FH option**, in addition to the basic and universal commands, is provided with Fieldcomm Group DD library and allows the configuration of specific parameters of each instrument.



IMPORTANT: Up to 15 instruments are allowed in a HART® network (addresses 1 to 15). In a connection to a single field instrument, the address value will be 0, on the INPUT mA + HART® connection, the primary variable can be read both analog and digitally (HART®).

The description presented below is valid for the CH and FH options.

2.5.1. HART® Connections

When selecting HART[®] in the main menu, the INPUT **mA + HART[®]** and **HART[®] ONLY (INCLUDING NETWORK)** options will be displayed on the screen. In the lower corner, press the check box to enable the use of the built-in resistor (250 Ω) according to the type of connection to be made.

The mode definition must be performed according to the type of connection to be performed by the user.

a) mA Input + HART[®]

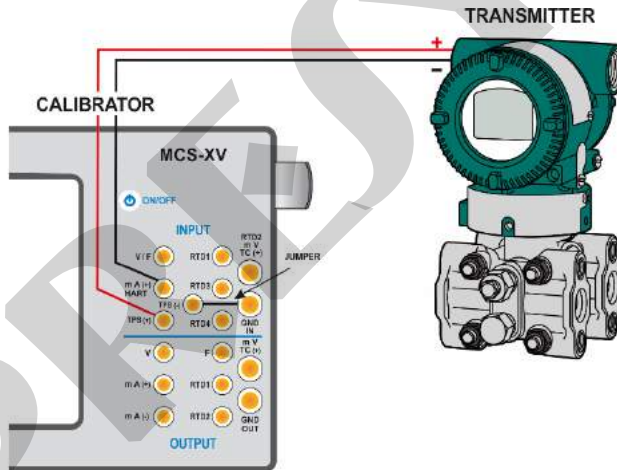

**Fig. 43 - Transmitter Powered by the Calibrator Itself (TPS)
mA Input + HART[®] (Internal Resistor Enabled)**

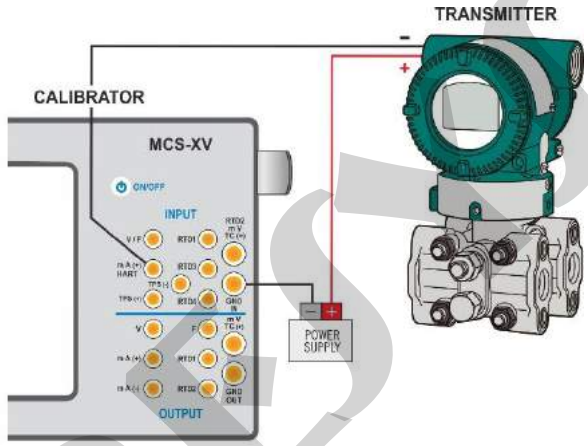

**Fig. 44 - Transmitter Powered by an External Power Supply
mA INPUT + HART® (Internal Resistor Enabled)**

For connections displayed in **Fig. 43** and **Fig. 44**, use the **mA Input + HART®** and **INTERNAL RESISTOR** option enabled. In this mode, the 250 Ω resistor is activated internally, in series with the mA input of the calibrator. In this way, the calibrator will be able to measure the current of the transmitter, as well as read and configure parameters via HART®. If the internal resistor is not enabled, an external resistor of at least 150 Ω in series with the mA input must be inserted. To power the transmitter, the TPS source of the MCS-XV (**Fig. 43**) or an external source can be used (**Fig. 44**).

b) ONLY HART® (INCLUDING NETWORK)

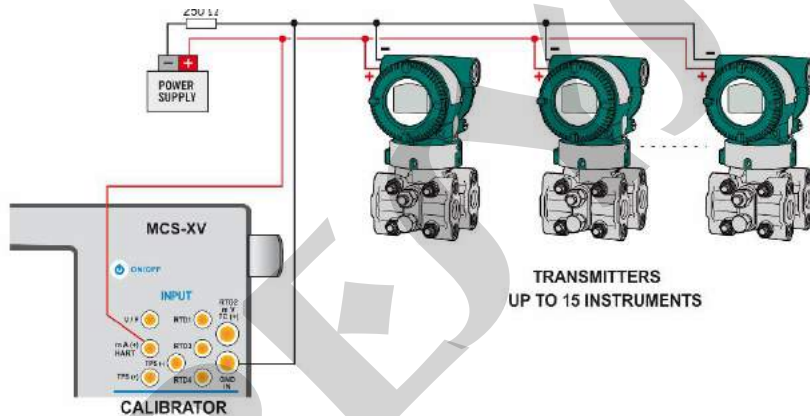

Fig. 45 - Only HART®



IMPORTANT: Before connecting the calibrator to the transmitter as shown above, ensure that the mA Input is not selected in the MCS-XV (enter in the Calibrator menu, and select any CH-1 Input other than mA or none).

For the connection shown in Fig. 45, use the HART® ONLY option. In this mode, the internal resistor and mA input are disabled. The HART® resistor of at least 250 Ω must be inserted externally in series with the power supply and transmitter.



IMPORTANT: This setting **DOES NOT ALLOW** the calibrator to read current from the transmitter, but the transmitter will still be able to read and configure its parameters via HART®.

2.5.2. Starting Communication

Entering the **HART®** menu, the following screen is shown. Enabling the **HART® CONFIGURATOR** option (only for **FH** version), you have access to the Full-Hart software (DD library) with all device parameters.

Disabling this option, the **CH** software is launched with basic and universal commands for HART® communication (zero, span, trim mA etc.).

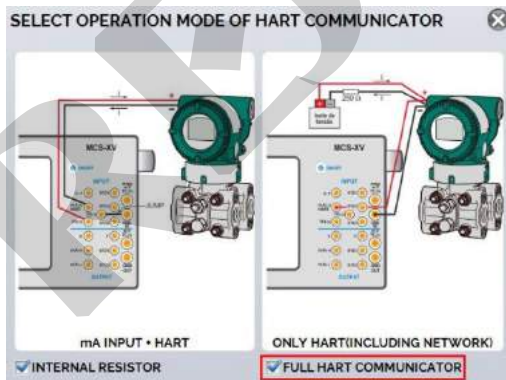

Fig. 46 – Enabling the FH Function

Enable the use of the internal resistor (250 Ω) and the HART[®] connection type configuration (**mA Input + HART[®]** or **HART[®] only**). For CH mode, in the next window, select the address of the instrument to establish the communication. If the address of the instrument is unknown, tap the **SEARCH** button. The calibrator will then perform a scan for all devices that are connected in an address range from 0 to 15. If the calibrator has found the device, you can press the **STOP** button, located in the lower right corner of the screen to cancel the scan.



NOTE: Up to 15 instruments are allowed in a HART[®] network (addresses 1-15). In a connection with a single field instrument, the address value will be 0. In the mA + HART[®] INPUT connection, the primary variable can be read either analog (4 to 20 mA) or digital (HART[®]). In the network connection, the only way to read the primary variable is digitally (HART[®] ONLY)

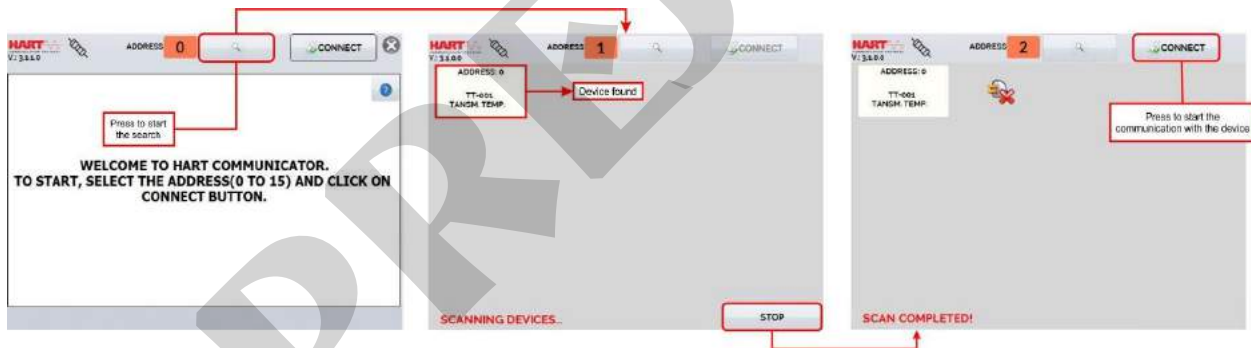

Fig. 47 – Communicating with the device

2.5.3. Adjusting the Measurement Range of a HART® Transmitter (CH Option)

When connecting, appears in the **DESCRIPTION** a tab data identifying the instrument, such as TAG, manufacturer, description, message, date, measuring range and input filter (damping). Some of these parameters can be changed in the **DEFAULT SETTINGS**.

The **MIN** and **MAX** fields indicate the measuring range of the HART® transmitter. For PV (primary variable) equal to the MIN value, the transmitter should generate 4 mA. For PV (primary variable) equal to MAX value, the transmitter should generate 20 mA.

The Transmitter maximum allowable range is shown just above (**RANGE**). To edit the range of the Transmitter, just change the **MIN** and **MAX** values and press the **SAVE RANGE** button. On this screen, it is possible to edit the unit of the primary variable and the input filter (damping).

HART V: 3.1.0.0

ADDRESS: 0 CHANGE DISCONNECT

GENERAL INFO

MANUFACTURER: PR Electronics

REVIEW: 5

TAG: TT-001

DATE: 5/10/2022

MESSAGE: ABC

DESCRIPTOR: TANSM. TEMP.

Range: -200 .. 850 °C

MIN: 0 MAX: 200 UNIT: °C FILTER(S): 0.4

SAVE RANGE SAVE FILTER

DESCRIPTION DEFAULT SETTINGS MONITORING

Fig. 48 - Adjusting the measuring range of the HART® transmitter®

2.5.4. Adjusting the Measurement Range of a HART® Transmitter with Reference (CH Option)

The range of the transmitter can also be adjusted generating the minimum and maximum values of the desired range in the transmitter input and adjusting these values as minimum and maximum (**set by reference**).



Select Input mA and press the **HART®** button. Connect the transmitter to the mA input. The reference value inserted in the transmitter input can be generated or measured by the MCS-XV itself. For this, before connecting the HART® instrument, from the main menu, select **CALIBRATOR**, and select on **Channel 2** the type of desired signal.

Example: To adjust the range of a Pt-100 temperature transmitter, select the **Pt-100 output option from the CALIBRATOR** menu and connect to the transmitter input. For a pressure transmitter, Channel 2 must be set to **Pressure** input and the pressure must be generated manually (with a pump, for example) and connected to the MCS-XV.

To enable Channel 2 as input, press the icon  → **CH-2**. To enable Channel 2 as output, disable **CH-2** option. To return to the calibrator screen press the **BACK** button. The signal measurement or generation of Channel 2 will work as the standard value for the adjustment range of the instrument.



Fig. 49 - Quick Hart® Adjustment with Reference

Using the calibrator 's output or other generator pattern, enter the signal corresponding to the lower value of the range into the transmitter input and press the  button and the transmitter should generate 4 mA for this value. Then generate the signal corresponding to the top value of the range and press the  button and the transmitter will generate 20 mA for this value.

Another way of doing the range adjustment by reference is entering in the **HART®** option. Back to the main menu by pressing the icon  and the **HOME** button. Select **HART®**, set the connection type, address, and then press **CONNECT**.

For this setting, select the **MONITORING** tab. In this screen are shown the value of the primary variable (PV) read by HART® (digital), the current that the transmitter wants to generate (**AO - DIGITAL OUTPUT**), and the current measured by the MCS-XV (**ANALOG READ**).

To adjust the range of the transmitter, generate the signal to the transmitter input corresponding to the lower range value and press the **↓ Inf Range** button. Transmitter will generate 4 mA to this value. Generate the signal to the transmitter input corresponding to the upper range value and press **↑ Sup. Range**. Transmitter will generate 20 mA for this value.



Fig. 50 Adjusting the Measuring Range of the HART[®] Transmitter with Reference

In **MONITORING** screen, beyond stating the primary variable PV and the transmitter current, is shown the measured or generated value by the MCS-XV in Channel 2. If the Channel 2 is configured as an output, click on the number to change the value of output.

2.5.5. HART[®] Transmitter mA Output Adjustment

Access the HART function[®] from the Calibrator Home Screen and, after connecting the instrument, press the **CONFIG** tab button. In this section it is possible to adjust the current output of the HART[®] transmitter (*Output Trim*) according to the current measurement of the MCS-XV. This adjustment can be made only when the MCS-XV is connected to a single transmitter with address 0, with the connection standard **mA INPUT + HART[®]**, considering that the calibrator must measure the current to perform the adjustment.

Before the adjustment process is started, the transmitter's current output can be checked by pressing the **CHECK** button. The transmitter will generate fixed currents comprising the values 4 mA, 8 mA, 12 mA, 16 mA and 20 mA. The calibrator will then indicate the measured values at each point.

To make the adjustment automatically, simply press the **AUTO** button. The MCS-XV will send a command to the transmitter to generate 4 and 20 mA (*fix*). After signal generation, the calibrator will measure these points, and adjust the output (*trim*). The adjustment is complete when the **D/A Completed** message is displayed.

The **LEAD TIME** field sets the stabilization time (in seconds) for each point.



Fig. 51 - Checking / Adjusting the mA HART® Transmitter Output

2.5.6. FULL HART[®] Configurator (FH)

If the **FULL HART[®] CONFIGURATOR** option is enabled, the FH software starts to run. In this mode, the device is automatically found, and the screen presents the complete parameters tree of the connected device.

To use Full HART[®] mode, on the home screen, press the **HART[®]** button and then make the electrical connection of the instrument to the calibrator terminals, select the operation mode, from the available options and select the option Full HART[®] Communicator in the check box located in the lower right corner of the screen.

To start the HART[®] configurator, wait for the MCS-XV to identify and read all instrument parameters. The Isocal MCS-XV will display the message: **Reading device information. Please wait...**

Once connected, information such as TAG, connected instrument model, and Device Description (DD) file will be displayed in the bottom corner of the screen.

To open the instrument configuration tree, select the Device Setup folder by pressing it twice in a row to navigate between the parameters available for your device, switch between folders, and change the information you want. The configuration tree changes according to the instrument, as each HART[®] transmitter has specific commands.

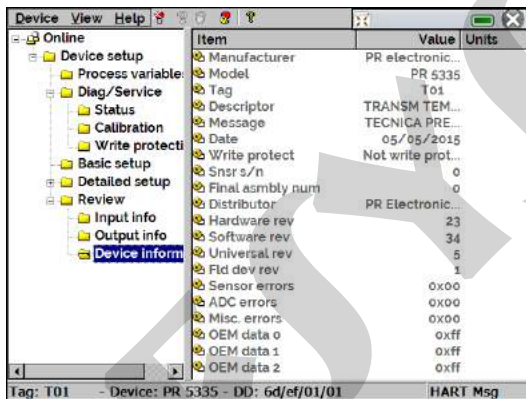



Item	Value	Units
Manufacturer	PR electronic...	
Model	PR 5335	
Tag	T01	
Descriptor	TRANSM TEM...	
Message	TECNICA PRE...	
Date	05/05/2015	
Write protect	Not write prot...	
Snsr s/n	0	
Final assembly num	0	
Distributor	PR Electronic...	
Hardware rev	23	
Software rev	34	
Universal rev	5	
Fid dev rev	1	
Sensor errors	0x00	
ADC errors	0x00	
Misc. errors	0x00	
OEM data 0	0xff	
OEM data 1	0xff	
OEM data 2	0xff	

Tag: T01 - Device: PR 5335 - DD: 6d/ef/01/01 HART Msg

Fig. 52 – Device Parameters

Double-click the parameter you want to change and edit the desired value.

Parameters identified with the icon  have methods. To change them, just double-click the parameter and follow the steps shown.

For other parameters, after editing the value the field becomes yellow, indicating that it has been changed, but not saved in the transmitter yet. To confirm click on the button . To cancel, press .

To view the MCS-XV mA input value or change the output setpoint, press the  button:

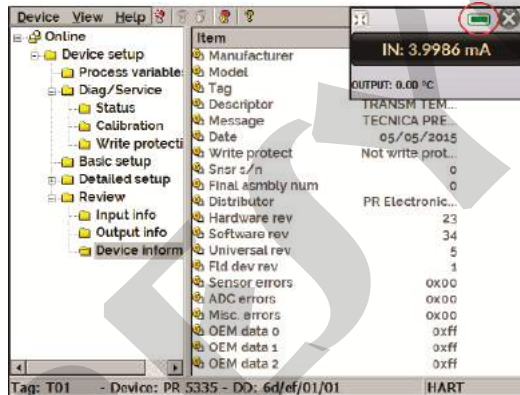

Fig. 53 - MCS-XV Input and Output Values

To view the device status, press the **VIEW** menu and **DEVICE CONDITION**:

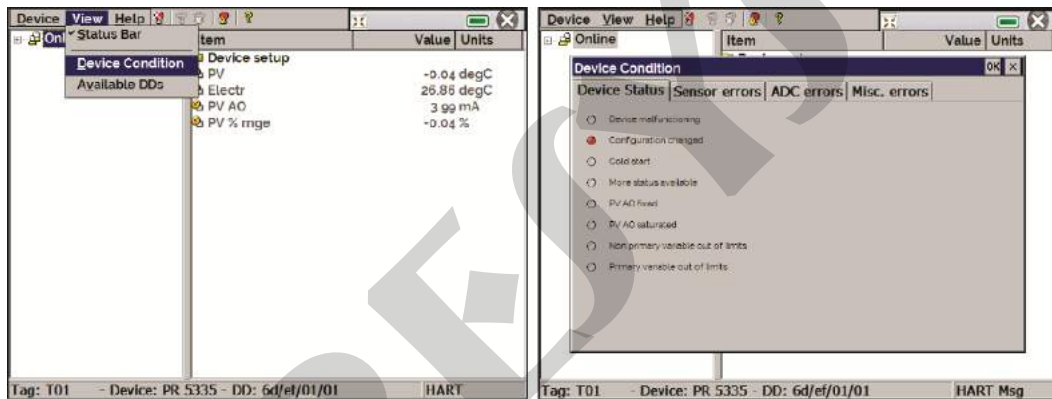

Fig. 54 – Device status

2.5.6.1 Saving a device configuration in FULL HART®

To save the settings of a HART® device connected to the calibrator, use the Document Device function. This function is intended to save the configuration of an instrument for later download on another device of the same model or to perform a backup of the applied settings.

Press the **Device** menu, located in the upper-left corner of the Full-HART[®] configurator window, then press the Document **Device option**. In the following pop-up, change the file name and write a note about it. To save it, press **Save Device Config** and then a new pop-up will appear on the screen stating that the configuration storage has been completed. Press the **OK** button to exit the windows.

When you need to upload the saved information to an instrument, go to the Device menu and then download/view. To select the configuration file, double-click on it. Press the WRITE button to download the configuration file for the connected instrument.

Before the instrument is fully configured, some confirmation messages will be displayed. To cancel, press X and to proceed with the operation, press **OK**. At the end of the configuration, the Configuration Write Complete message appears.

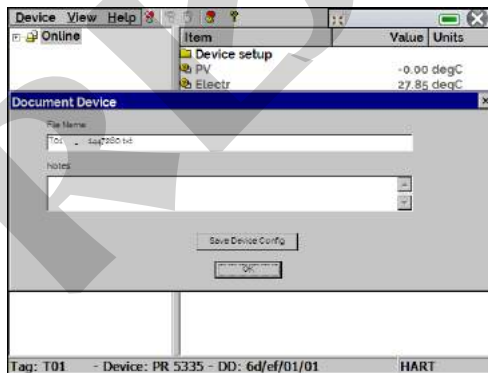

Fig. 55 - Saving the device configuration

2.6. Profibus®

You can connect the calibrator to devices in two ways: using the internal power supply or an external power supply. When using an external power supply, it may be necessary to use a 50 Ω resistor, in these cases, check the technical manual of the device you want to calibrate.

However, when defining the use of a power supply in accordance with Profibus®, or the internal power supply of the calibrator, the installation of the resistor will not be necessary. Below, **Fig. 56** and **Fig. 57** indicate the necessary connections.



Fig. 56 - Connecting through the internal source

Fig. 57 - Connecting through the external source



ATTENTION: Do not connect two master devices at the same time in the same segment. This action may make Profibus® communication unstable.



ATTENTION : By default, the internal 24Vdc font is enabled for use. If an external source is required, disable the function by pressing the selection key, as indicated in Fig. 59

2.6.1. Profibus® Communication

The ISOCAL MCS-XV allows the calibration of instruments that have Profibus® communication protocol. Through an easy and intuitive menu, it is possible to calibrate one or more devices at the same time without the need for an external power supply.

To configure Profibus® input, on start page press the **Calibrator** menu and then the **INPUT** bar, located in the lower corner. Find the Profibus® option and select it.



Fig. 58 - Profibus® input selection

On the next screen, the Profibus® configuration panel will be displayed.



Fig. 59 - Profibus® Configuration Screen

The **Internal 24 V Power Supply** selection chooses whether internal 24 Vdc supply is used or not. When using an external power supply, ensure communication by using a Profibus® compliant power supply or add a resistor between the power supply and the bus.

Press the **Live List** button to start scanning for devices on the network. Press the Stop **Live List** button to cancel the scan.

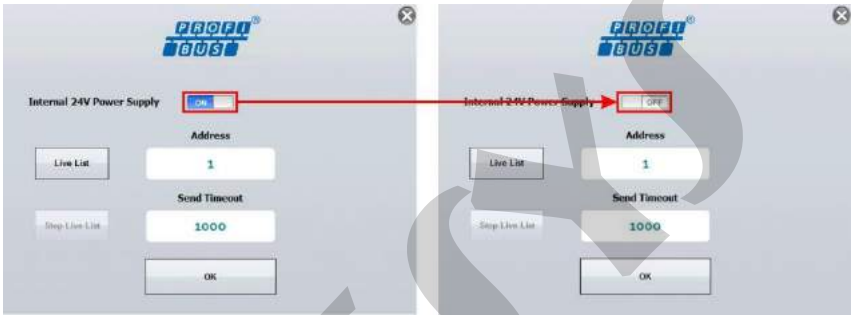

Fig. 60 - Enabling the internal power supply

If the calibrator finds a device, a confirmation message appears.



Fig. 61 - Confirmation message

If there is a problem while searching for devices, an error message appears.

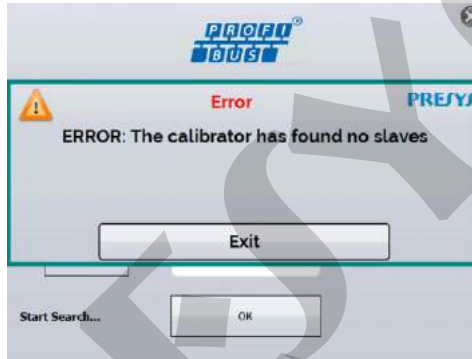

Fig. 62 – Error message

If the calibrator identifies a device, its address field is set automatically. You can also enter the address manually by pressing the addressing field. After setting up, press the **OK** button.



Fig. 63 - Profibus® screen

Configure the number of decimal places of the variable displayed by the connected device. Press the button **SIGNAL: PROFIBUS®**, located in the upper left corner of the screen and select the desired number of decimal places. Then press **HIDE STATUS** to close the menu.



Fig. 64 – Decimal places configuration

Press the Profibus[®] icon to adjust some Analog Input (AI) parameters:



Fig. 65 - Profibus[®] parameters selection

Each button function is described below:



Opens the analog input configuration screen to adjust the lower parameters of the block.

Opens



the analog input configuration screen to adjust the block's upper parameters.



Forces reset of Profibus[®] module. This function can help to solve some problem in communication with the instrument. After pressing this button, wait for a few seconds to view the variable again.

The analog input block (AI) configuration screen is shown in the following figure. Only some (AI) block parameters can be changed by Presys calibrators.

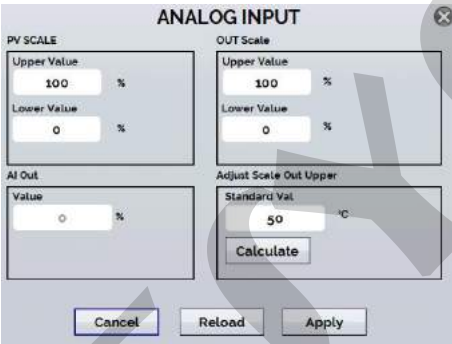

Fig. 66 – Analog Input Parameters Screen

The parameters that can be adjusted by Presys calibrators are as follows:

PV Scale: Adjusts the PV_SCALE parameter of the Profibus specification where **Upper Value** corresponds to a value in engineering unit of the transducer block that will be defined as 100% of the instrument's operating scale. The **Lower Value** parameter corresponds to a value in engineering unit that will be defined as 0% of the operating scale.

Out Scale: Adjusts the OUT_SCALE parameter of the Profibus specification where **Lower Value** and **Upper Value** correspond to the effective lower and upper value that will appear on the output of the analog input block. These values are related to the values of the PV Scale parameters where in simpler cases the values of PV Scale and Out Scale are equal.

AI Out: Shows the OUT value of the Profibus specification. This value will be used as the instrument's digital output value. **This value is read-only and cannot be changed.**

The above parameters can be changed, and the changes can be sent to the instrument using the **Apply** button. The instrument will be placed in **Out of Service mode** before attempting to save these parameters to the instrument. After saving the instrument is put back into **AUTO mode**. The **Reload** button allows to force a new reading of the values present in the instrument.

Adjust Scale Out: Value indicated by the Presys standard used normally to be compared with the AI Out value of the instrument. **Note that this parameter is not from the instrument being calibrated.**

Presys calibrators can help correct the value of the AI OUT parameter so that the value of the AI Out is closer to the standard value. This correction is performed as follows:

Step 1: Enter in the calibrator screen which shows the values at the input and output of the calibrator. Note that the calibrator input must present the value of the instrument's digital output.

Step 2: Change the calibrator output to generate the value defined in Lower Value of the PV Scale parameter, for example, 0°C.

Step 3: Wait some time for the Profibus instrument to stabilize.

Step 4: Press on the Profibus logo and then on the “-” button to return to the AI block parameters screen.

Step 5: If the standard is showing a correct indication, the **AI Out** value and **Standard Val** values must be close according to the instrument's tolerance. If there is divergence in the values, press the **Calculate** button where the calibrator will calculate the value of the **Lower Value** parameter, subtracting the indication error according to the formula below.

$$LVNEW = LV - (AIOUT - Standard)$$

Where:

LVNEW: new value of the Out Scale parameter **Lower Value** where the error of the instrument's digital output was discounted.

LV: current value of the Out Scale parameter **Lower Value**.

Standard: Standard value read by the Presys calibrator or entered by the user if the output of the Presys calibrator is not being used.

Step 6: Check the calculated value and press the **Apply** button to save the data in the instrument. If necessary, you can try to repeat the previous steps to make a new adjustment.

The same procedure described in the steps above can be done for the value of Out Scale **Upper Value**.

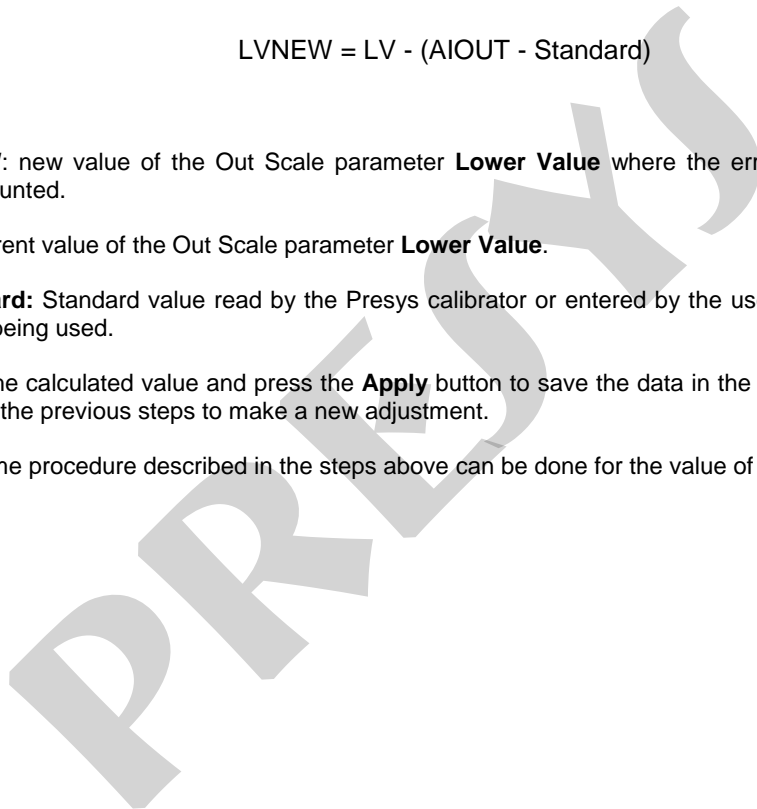

2.7. Data Logger

The MCS-XV allows you to record series of measurements over time to display data in chart or table format. Select **CALIBRATOR** from the main menu and select the desired type of signal on channel 1 and channel 2.

Press the icon  and select **DATA LOGGER**. The calibrator automatically starts the measurements and displays each measured point on the chart.

To save the measurements, press the **REC** button (see **Fig. 67**), with this function, the collected data is saved in a file in the internal memory and can be used to generate graphs or tables.



Fig. 67 - Data Logger



Fig. 68 – Data Logger Configuration menu

Entering in the Configuration Menu (indicated by the icon ) , in **CONFIG** option, you can edit the background color of the chart, color and line thickness, sampling rate (in seconds) and set the x (time) and y (measurements) axis of the chart.

Recording can also be programmed to start at a certain date and time in the **LOGGER** option. Just set the start time and end time of recording. During the defined range, the measured points are saved in an internal file in MCS-XV.

To view a saved file, press the **OPEN** button, select the desired file, and press **LOAD**. The file name contains the date and time of the measurements.

The **SHEET** button allows the visualization of data in table format, with the date and time of the measurement and the measured values.

If the user wants to export the current data to a .csv file that can be opened in spreadsheet software, press the **SAVE** button, and indicate the name and where it will be saved. The button  saves the current screen image as a .png file. All saved screens can be viewed in the **IMAGE** menu.

These files are saved in the internal SD card of the calibrator. If a USB Pen Drive is connected to MCS-XV, you can choose between saving in the internal SD card or the Pen Drive.

2.8. Automatic Tasks

The MCS-XV can generate and performing automatic calibration tasks. This function can be used to generate work orders for several instrument types, as well as integrate with ISOPLAN[®] calibration management software, integrating reliability and convenience to the main activities involved.

The tasks can be generated from the calibrator or through a computer connection. It is also possible to add other methods of automatic task generation using the ISOPLAN[®], proprietary applications, .xml files that contain calibration instructions, remote servers, and even programs generated by Excel VBA.

In addition to automatically performing work orders, the Tasks section is also capable of autonomously generating reports, storing them, and remotely printing them. All these features are protected by end-to-end encryption, ensuring the security of the files generated during the calibrations.

2.8.1. Creating Tasks

a) Tasks Information

To create tasks from the main menu, select **CALIBRATOR**. Select the desired type of signal on channel 1 and channel 2. For example, to calibrate a thermocouple temperature transmitter, select TC output (which will be connected to the transmitter input) and mA input (which will be connected to the current output of the transmitter). For a voltage indicator, e.g., selected output V (which is connected to the indicator input) and NONE for the input (the instrument reading will be inserted manually).

Press the icon , select **TASKS** → **CREATE NEW TASK**. In the Task Info., insert in the indicated fields the data related to the calibration procedure relevant to the task report, the fields in yellow are mandatory.

Fill at least the serial number of the instrument to be calibrated, instrument TAG, stabilization time for each point (waiting time in seconds) and the maximum error allowed for the instrument to be calibrated (in % of the span, reading or full scale).



IMPORTANT: By filling the stabilization time with the value 0 (zero), the calibrator requests to the operator to manually confirm point acquisition.

OPEN TEMPLATE	
CREATED BY	Smith, John
MANUFACTURER	Presys
MODEL	TT223
MESSAGE	Example
AREA	
CUSTOMER	Presys Instrumentos
SERIAL NO.	182.05.14
TAG	To5
ERROR SOURCE	SPAN
SETTLING TIME(S)	15
MAX ERROR (%)	0.250

Fig. 69 – Task Information

b) Defining Points and Strategy

After finishing setting up the device under test and the procedure information, select in the lower corner the AsFound/AsLeft tab to determine the method of task execution.

- **Expected:** expected value at the auxiliary input.
- **Point:** defined point for calibration execution.
- **Rep:** number of repetitions of the calibration cycle.
- **Strategy:** method by which the calibration is performed, following a logical sequence to go through the points, which can be from minimum point to maximum point (↑), from maximum point to minimum point (↓) etc.



IMPORTANT: If the As Found repetitions method are set to 0 (zero), the task will contain only As Left calibration.

Add each calibration point and corresponding expected value (expected Channel 1 - calibrator input), both As found (calibration done before adjustment) and As left (calibration done after adjustment, **if it is used**).

The points can also be generated with the help of the **AUTO** button. By pressing this button, just enter the maximum and minimum values of the calibration range and the number of points and a list of points will be generated considering equal steps and a linear scale.

Also fill in the number of repetitions (rep.) of the readings, and the calibration strategy (start to end point ↑, end to start point ↓, etc.). By filling the as found **REP** field of the with the value 0, the task will only have the As left calibration. The **REP** field of the as left calibration must be filled in with the minimum value 1.

AS FOUND

EXPECTED	<input type="text"/>	mA	0.00	4.0000	<input type="button" value="+"/>
POINT	<input type="text"/>	°C	75.00	8.0000	<input type="button" value="X"/>
REPETITIONS	0	<input type="button" value="AUTO"/>	150.00	12.0000	<input type="button" value="🗑"/>
STRATEGY	<input type="button" value="↑"/> <input type="button" value="↓"/> <input type="button" value="↕"/> <input type="button" value="↔"/>		225.00	16.0000	
			300.00	20.0000	

AS LEFT

EXPECTED	<input type="text"/>	mA	0.00	4.0000	<input type="button" value="+"/>
POINT	<input type="text"/>	°C	75.00	8.0000	<input type="button" value="X"/>
REPETITIONS	3	<input type="button" value="AUTO"/>	150.00	12.0000	<input type="button" value="🗑"/>
STRATEGY	<input type="button" value="↑"/> <input type="button" value="↓"/> <input type="button" value="↕"/> <input type="button" value="↔"/>		225.00	16.0000	
			300.00	20.0000	

RANGE 4.0000 ... mA

Task info AsFound/AsLeft Review and Save

Fig. 70 – Task Points and Strategy

Select the **Review and Save** bar. Choose a name/identification number for the task. To save the template of this task for later use in creating other service orders, press **SAVE TEMPLATE** and name it. To open this template again, in the task creation screen, press **OPEN MODEL**.

Click **CREATE** to save the task. The task is now saved in the calibrator and can be executed

TASK DETAILS

CREATED ON: 09/05/22
CUSTOMER: Presys Instrumentos
ADDRESS: Rua Luis da Costa Ramos, 260 - Saúde - São Paulo - SP
INSTRUMENT DETAILS:
TAG: To5
SERIAL NUMBER: 182.05.14
MODEL: TIC-X
MANUFACTURER: Presys
INPUT RANGE: 0 to 300 °C (RTD)
OUTPUT RANGE: 4 to 20 mA
SETTLING TIME: 15 SECONDS

IDENTIFICATION

OS01

SAVE TEMPLATE CREATE

Task Info AsFound/AsLeft Review and Save

Fig. 71 – Reviewing and Saving the Task

2.8.2. Executing Tasks

To perform a task created from the main menu select **TASKS** → **EXPLORE TASKS**. A list identifying the created work orders that have not been performed yet (● **WAITING**) is shown. Select the desired task and press **OK**. Make the necessary connections between the calibrator and the instrument to be calibrated and press **START**.

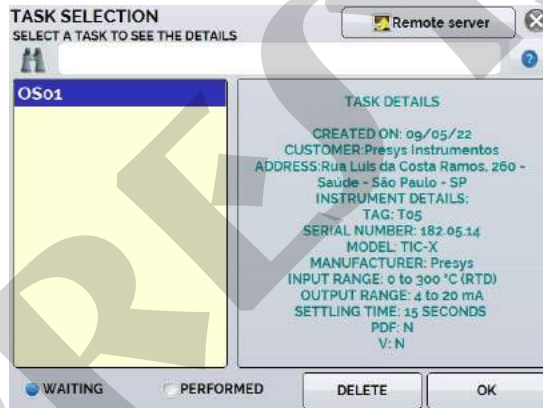

Fig. 72 – Viewing task information

The MCS-XV automatically starts to do the calibration generating setpoints registered on task and reading the instrument to be calibrated.



IMPORTANT: If **NONE** is selected for the calibrator input or output, the calibrator prompts you to enter the data manually. The result is shown on the screen, a progress bar indicates the remaining calibration time.

At the end of the calibration, a report is shown with the generated values, the obtained values, the expected values, and the error verified. If the error is higher than the registered value for the task, the line appears in **red**.

The first time a task is executed, it is saved as **found** (before adjustment). If it is run again, it will be saved as **left** (after adjustment). Tasks created with only **As left** are run only once. The results are saved in the calibrator and can be viewed at any time in the **PERFORMED** option.

2.8.3. Viewing Results

Once a task has been performed, it remains saved in the calibrator. To view the results of a calibration in MCS-XV, in the main menu select **TASKS** → **EXPLORE TASKS**.

Select the ● **PERFORMED** option. The list will now display only those tasks that have already been performed. Select the desired work order and press **OK**. The next screen will show the report with the calibration points, the obtained values, expected values and the verified errors. If the error is above the value registered for the task, the line appears in **red**.

POINT	EXPECTED	OBTAINED	ABS. ERR.	SPAN ERR.
0.00 °C	4.0000 mA	3.9950 mA	-0.0050 mA	-0.031%
125.00 °C	8.0000 mA	7.9936 mA	-0.0064 mA	-0.040%
250.00 °C	12.0000 mA	11.9977 mA	-0.0023 mA	-0.014%
375.00 °C	16.0000 mA	16.0020 mA	0.0020 mA	0.013%
500.00 °C	20.0000 mA	20.0063 mA	0.0063 mA	0.039%
500.00 °C	20.0000 mA	20.0067 mA	0.0067 mA	0.042%
375.00 °C	16.0000 mA	16.0030 mA	0.0030 mA	0.019%
250.00 °C	12.0000 mA	11.9988 mA	-0.0012 mA	-0.007%
125.00 °C	8.0000 mA	7.9946 mA	-0.0054 mA	-0.034%
0.00 °C	4.0000 mA	3.9959 mA	-0.0041 mA	-0.026%

AS-FOUND AS-LEFT AS-FOUND ERR. AS-LEFT ERR. DETAILS

Fig. 73 – Tasks Results

CREATE DOCUMENT option saves the job data as a .pdf extension file to the calibrator's internal memory (SD card), which can be printed or accessed via a computer.

To print the Calibration Report, press the icon . The printer must have been previously configured in **SETTINGS** → **SYSTEM** tab → **PRINTER CONFIG.** (See section **3.4 – System**) and connected to the MCS-XV USB Host port (see **Fig. 02, 04** and **05**, portable, RM and DT versions, respectively). Tasks are saved in the **TASKSREPORTS** folder, identified by the number of the registered TAG.

To save all the tasks in a Pen Drive or external HD connected to the calibrator, enter the **TASK** → **ADVANCED TASK OPTIONS** → **EXPORT FILES TO USB FLASHDRIVE.**

The logo can be changed to one of your own company. To do so, plug a Pen Drive with the logo file into the MCS-XV USB port. Enter the **TASKS** → **ADVANCED TASK OPTIONS** → **ADVANCED** → **CERTIFICATE MODEL MANAGER** → **LOGO** and select the file by its name (must have the extension **.jpg**). We recommend an image size of approx. 200 x 200 pixels.

To add your sign to the Report, create a user with a signature in **System** menu (See section 3.4.5 – Security Options) and enable the **Protected Access** with password.

Calibration report for tag TT01

PRESYS

TASK DETAILS

CREATED IN: 03/02/2016
 INSTRUMENT DETAILS:
 TAG: TT01
 SERIAL NUMBER: 001.01.15
 MODEL: RTD Transmitter
 MANUFACTURER: Presys
 INPUT RANGE: 0 TO 100 °C (RTD)
 OUTPUT RANGE: 4 TO 20 mA
 MAX ERROR = 0,1% SPAN (SPAN = 16 mA)
 LEAD TIME: 10 SECONDS

As-found performed by: John A.

POINT	EXPECTED	OBTAINED	ERROR	SPAN ERR.	PASS/FAIL
0.00 °C	4.0000 mA	3.9955 mA	-0.0045 mA	-0.028%	Pass
25.00 °C	8.0000 mA	7.9907 mA	-0.0093 mA	-0.058%	Pass
50.00 °C	12.0000 mA	11.9897 mA	-0.0103 mA	-0.064%	Pass
75.00 °C	16.0000 mA	15.9934 mA	-0.0066 mA	-0.041%	Pass
100.00 °C	20.0000 mA	19.9968 mA	-0.0032 mA	-0.020%	Pass

As-left performed by: John A.

POINT	EXPECTED	OBTAINED	ERROR	SPAN ERR.	PASS/FAIL
0.00 °C	4.0000 mA	4.0001 mA	0.0001 mA	0.001%	Pass
25.00 °C	8.0000 mA	7.9949 mA	-0.0051 mA	-0.032%	Pass
50.00 °C	12.0000 mA	11.9911 mA	-0.0089 mA	-0.056%	Pass
75.00 °C	16.0000 mA	15.9932 mA	-0.0068 mA	-0.042%	Pass
100.00 °C	20.0000 mA	19.9957 mA	-0.0043 mA	-0.027%	Pass
100.00 °C	20.0000 mA	19.9983 mA	-0.0017 mA	-0.011%	Pass
75.00 °C	16.0000 mA	15.9995 mA	-0.0005 mA	-0.003%	Pass
50.00 °C	12.0000 mA	11.9924 mA	-0.0076 mA	-0.047%	Pass
25.00 °C	8.0000 mA	7.9975 mA	-0.0025 mA	-0.016%	Pass
0.00 °C	4.0000 mA	3.9981 mA	-0.0019 mA	-0.012%	Pass

Standard serial number: 112.11.15
 Standard last calibration: 13/11/2015
 Operator signature: 

Fig. 74 – Calibration Report Example

2.8.4. Task Advanced Options

In the **Advanced Task Options** menu, by clicking on **ADVANCED** it is possible to configure/ register the following options: Costumer Manager, export task files to an USB flash drive and enable or disable the files encryption.

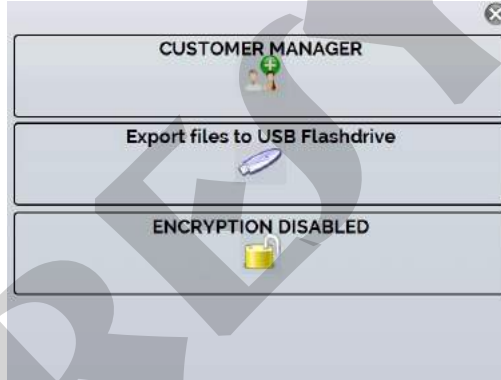

Fig. 75 – Task Advanced Options

2.9. Help Desk

MCS-XV calibrator has a video player and documents viewer. These videos can be viewed while a calibration is performed and are designed to assist in the use of the calibrator. Documents can be, for example, procedures or instructions that can be stored and viewed on the calibrator itself.



Fig. 76 - Help Desk

From the main menu, selecting **HELP DESK** and the tab **VIDEOS** a list of video categories appears. Select the category and the desired video. Press the button **FULL SCREEN** to view the video in full screen and the button **WINDOW** to reduced screen.

To add recent videos on the calibrator, connect the USB cable to the computer (type A USB) and to the MCS-XV (Type B USB, see **Figures 02, 04** and **05**, portable, RM and DT versions, respectively). Open **VIDEOS** folder. Copy the new video to any sub-folder (category) of the **VIDEOS** folder. If you prefer to create a new category, simply create a new folder inside **VIDEOS** with the name of the desired category and copy the video to this folder.

To insert documents, such as procedures or instructions, files must be converted to .pdf and be saved into the SD card **HELP folder**. We recommend that the file be in presentation format, for better viewing on the calibrator screen.



Fig. 77 – Documents tab

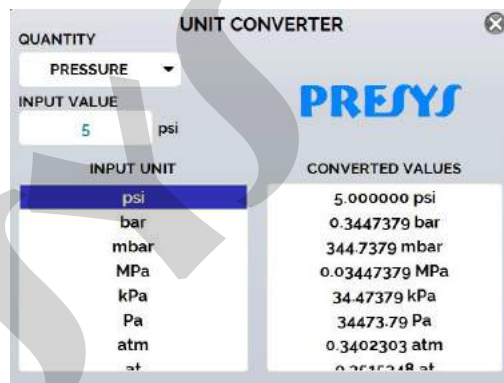

Fig. 78 – Utilities tab

3. SETTINGS

The **SETTINGS** menu has four divisions (tabs at the bottom): **DATE AND TIME**, **NETWORK**, **SERVICES** and **SYSTEM**, described below:

3.1. Date and Time

In the Date and Time bar you can set the date and time, time zone for the calibrator, as well as the time format from the available options. You can also set the decimal separator for CSV files between comma and period.

After finishing your changes, press **OK** to store the new configuration parameters.



Fig. 79 – Date and Time configuration

3.2. Network

In the **NETWORK** tab you can configure the calibrator IP address for communication with the computer and Wi-Fi (wireless) network.



NOTE: The IP address can be dynamically configured (**DHCP**) or can be fixed address (Disable DHCP and change desired addresses).

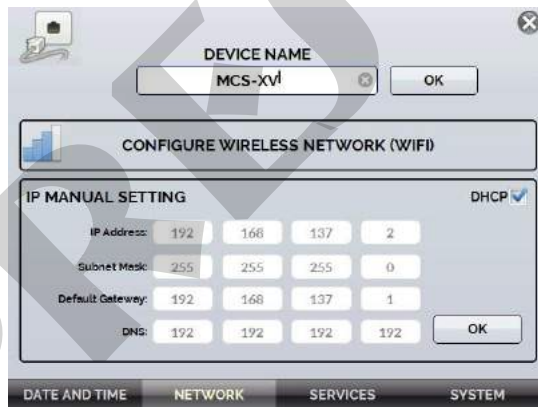

Fig. 80 – Network configuration

3.2.1. Naming the Calibrator

To name the calibrator to make it easier to find it in a network with many devices, press the **DEVICE NAME** field, alter the value, and press the **OK** button. Then, restart the calibrator to store the added information.

3.2.2. Altering the IP Address

In the **IP MANUAL SETTING** field, select the check box **DHCP** to enable the dynamic IP configuration, so the calibrator will set it automatically.

To manually configure the calibrator IP, clear the check box **DHCP** and enter the desired values in the **IP Address**, **Subnet Mask**, **Default Gateway**, and **DNS** fields, if required.



Then press the **OK** button. To store the current information, restart the calibrator.

3.2.3 Setting up Wireless Network (Wi-Fi)

Communication via Wi-Fi is performed through the USB/WIFI adapter. To set up access to a wireless network, press the **CONFIGURE WIRELESS NETWORK (WIFI)** button. On the next screen, search in the field **VISIBLE NETWORKS** the Wi-Fi network you wish to connect to and press the **CONNECT** button. Enter the network password and change the WPA type (if required), press **OK** to store the information.

When you are done configuring, the connected network will be displayed in the **KNOWN NETWORKS** field. To delete a saved network, simply select it and press the **DELETE NETWORK** button.

3.2.4. Viewing IP Address

When the calibrator is connected to the network it is possible to view and print Task Reports from your computer. Press the network icon  to access the configured IP address once connected to the network. When connected to a wireless network, the Wi-Fi network icon  will be visible.

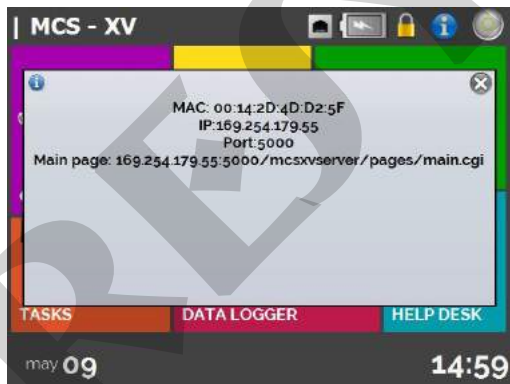

Fig. 81 – IP Address

3.3. Services

In the **SERVICES** the user can configure the calibrator's communication types, among other settings.

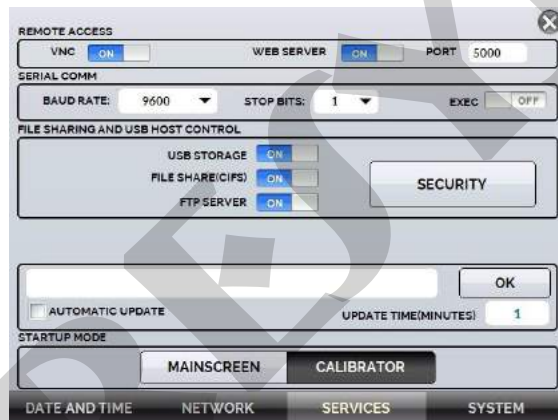

Fig. 82 – Services configuration

3.3.1. Remote Access

a) VNC

Virtual Network Computing (or **VNC**) is a graphical desktop sharing system that uses the Remote Frame Buffer Protocol (RFB) to remotely control another computer or device. By enabling this option, the calibrator's screen can be accessed directly on the computer.

For access via VNC you need to download and install a VNC viewer program, some are freely available on the internet. Connect the calibrator to the network via Ethernet cable or Wi-Fi. Configure in the VNC viewer the IP address indicated in the network icon (see **Fig. 56**) and connect.

When prompted, use the password "**adm**". This password can be changed later in **NETWORK → FILES SHARING AND UDB HOST CONTROL → SECURITY**.

Web Server

To access the calibrator's integrated Web Server, enable the option in the **NETWORK** tab. Connect the calibrator to the network via Ethernet cable or Wi-Fi and configure the communication port, if required

To access the Web Server, open the browser on your computer and enter the following address. To check the IP address.

<calibrator_IP_address>:5000/mcsxvserver/pages/main.cgi>

User: *admin*

Password: *xvmaster*

Presys MCS-XV WebServer

Not secure | 169.254.114.147:5000/mcsxvserver/pages/main.cgi

PRESYS MCS-XV

XV Dashboard

Sys Info

Input Signal

Output Signal

XV Screen

Pendent tasks 0

Completed tasks 26

MCS-XV Dashboard

4.0022 mA
Input CH1

0.00 °C
Input CH2/Output

SelfPoint
SetPoint GO

Notifications Panel

Presys MCS-XV
Welcome

Fig. 83 - Web Server page

On the Web Server, it is possible to monitor the calibrator screen, change the output type and value, and read signals from the inputs.

3.3.2. Serial Communication

The Isocal MCS-XV allows control of the inputs and outputs via serial communication. To control the calibrator using SCPI commands, connect a serial cable to the MCS-XV USB Type A port (see section **2.1 - Parts Identification**).

To enable the function, set the parameters and then press the **EXEC** key to the **ON** position.



NOTE: If a USB-to-Serial converter is not properly connected to the calibrator, an error message will be displayed when enabling the function. Reconnect and repeat the steps.

NOTE: When enabled, the icon  will be displayed on the Calibrator Start Screen.

a) SCPI Commands List

Communication Parameters:

Parity: none

Data bits: 8

Baud rate and Stop Bits: configurable on the SERIAL COMM menu.

Here are some examples of SCPI commands from the MCS-XV calibrator. For a complete list, please consult Presys.

***IDN?**

Description: Instrument identification.
Parameters: ---
Response: Manufacturer, ID, Serial Number, Software Version

***CLS**

Description: Clears the error list.
Parameters: ---
Response: ---

MEASure:PRESSure?

Description: Pressure reading
Parameters: ---
Response: Pressure reading | unit

UNIT[:PRESSure]?

Description: Current pressure unit.
Parameters: ---
Response: Current pressure unit.

UNIT[:PRESSure] <unit>

Description: Sets the unit of pressure.
Parameters: New pressure unit
Response: ---

SYSTem:ERRor[:NEXT]?

Description: Check the error list.

Parameters: ---

Response: Last Error

MEASure[:SCALar]:CURRent[:DC]?

Description: mA Input Reading

Parameters: ---

Response: mA Input Reading

MEASure[:SCALar]:VOLTage[:DC]?

Description: V Input Reading

Parameters: ---

Response: V Input Reading

3.3.3. File sharing and USB host control

Edit the sharing and security settings for access to the calibrator using the options available in this section.

a) Enabling file sharing

Change the state of the key ON to enable or disable the following functions:

- **USB STORAGE:** Access to the calibrator internal storage (SD Card). With this function enabled, when connecting the calibrator to the computer through a USB cable, the files stored in the internal memory can be accessed, changed and/or removed by the user. Disable to block access.
- **FILE SHARE (CIFS):** Allows the access to the calibrator's internal storage files via CIFS (Common Internet File System). Disable to block access.
- **FTP SERVER:** Allows access to files stored in the internal memory of the calibrator by applications that allow file transfer from one device to another, such as FileZilla, for example. Disable to block access.

b) Security

Press the **SECURITY** button to get access to the password setting for access to the File Share (CIFS), FTP Server and VNC sharing services.

To set a password, enter the desired value and repeat to confirm. Then press the **APPLY** button to save it. Press the button  to enable security. The calibrator must be restarted to enable access protection.

3.3.4. Server Communication

The Isocal MCS-XV calibrator allows connection to a remote server or application by simply typing the path in the address field and pressing the **OK** button. By checking the **AUTOMATIC UPDATE** checkbox and setting the time between checks (in minutes), the communication is updated according to specifications and independently.

3.4. SYSTEM

In the **SYSTEM**, configure options such as screen brightness and settings, calibrator identification, printer settings, security options, sound options, and language. You can also access the advanced system settings via this menu.

3.4.1. Touchscreen Options

Press the **ADJUST TOUCHSCREEN** button to calibrate the screen, by touching the center of the + signs on the screen (the use of a touch screen stylus is recommended). After calibration, press the screen again at any point. Confirm the adjustment and return to the **SYSTEM** screen.

Set the screen orientation by pressing the **ROTATE SCREEN (180°)** button. With each touch, the screen will rotate by 180°. Press  to exit the adjustment mode.

3.4.2. Screen Brightness

Adapt the screen brightness to the ambient conditions in this menu. The available adjustment options are: 25%, 50%, 75% and 100%.

3.4.3. Calibrator Identification



Define information such as location, owner, and calibrator tag. To change the data, press the blank field and type the desired content using the virtual keyboard. To save the information, press **SAVE INFO**, the **CANCEL** button aborts the operation.

3.4.4. Print Configuration

Press the **PRINTER CONFIG.** button to access the printer settings menu. Select the **DRAFT** check box to change the print quality. Press **OK** to save the information and the **CANCEL** button to cancel the operation.

3.4.5. Security Options

Security options allow the user to set access rules for users that use the calibrator. Initially, the Isocal MCS-XV has no password access. This setting can be changed in **SECURITY OPTIONS**.

To create a user, press the  icon and then the user icon . Select **NEW**, fill in the blanks and press **CREATE**. In the next window you can see the **User Manager**.

You can add a signature to be used when issuing the **TASKS** function reports and certificates. To do so, select the user and press **SIGN**. In the same way, an image can be associated with the user, to add it, connect a pen drive and press the **IMAGE** button, then select the image and save it.



Fig. 84 – Users Manager

Please note the functions that each user level has access to in the table below:

User Level	Function				
	Calibrator	Tasks	Hart®	Data-Logger	Configurations
Operator	✓	✓	✗	✗	✗
Tec	✓	✓	✓	✓	✗
Admin	✓	✓	✓	✓	✓

To limit access to the system, press the key icon  and then the padlock icon  in the **SETTINGS** → **SYSTEM** menu.

The next time the Calibrator is started, you will be prompted for login and password. To unlock the system, log in as an Admin level user and press the padlock icon until it is open again.



IMPORTANT: If no user has been registered, when pressing the  button and enabling security, the default user Admin is selected. When restarting the calibrator, it will ask for a password, type **123** to release it.



ATTENTION: Never delete all Admin level users when using password access!

3.4.6. Adjust Cal.

Adjustment Level, password protected. See section **4 - Adjust** for more information.

4. ADJUST



ATTENTION! Only perform the procedures in this section after you fully understand the information in this section. Failure to follow the warnings and information contained in these instructions may result in damage to the calibrator.



ATTENTION! Presys Instruments and Systems is not liable for any damage to the MCS-XV due to failure to follow the information provided.



ATTENTION: Be sure to use properly adjusted and calibrated standards. Failure to observe this recommendation may lead to loss of factory set points.



IMPORTANT: In some cases, the value entered into the instrument will not be saved on the first confirmation (button pressed), this condition can be easily noticed because the display indicates different values in relation to the point entered. In these occasions, perform the point saving operation a few more times using the PNT key. This condition repeats itself for other inputs.

To perform the calibration of the auxiliary inputs, in the Main Menu, press the SETUP button and scroll to the **SYSTEM** tab. Then press the **ADJUST CAL.** button located at the top of the screen. Enter the required password (**9875**) and press OK.

After entering the password, the screen displays the **GENERAL**, **INPUTS**, and **OUTPUTS** options. In the **GENERAL** option you can restore the factory adjustment file and change the date of the last calibration, if any adjustments have been made.

For adjustment, choose between inputs, outputs and pressure adjustment (**General** tab).

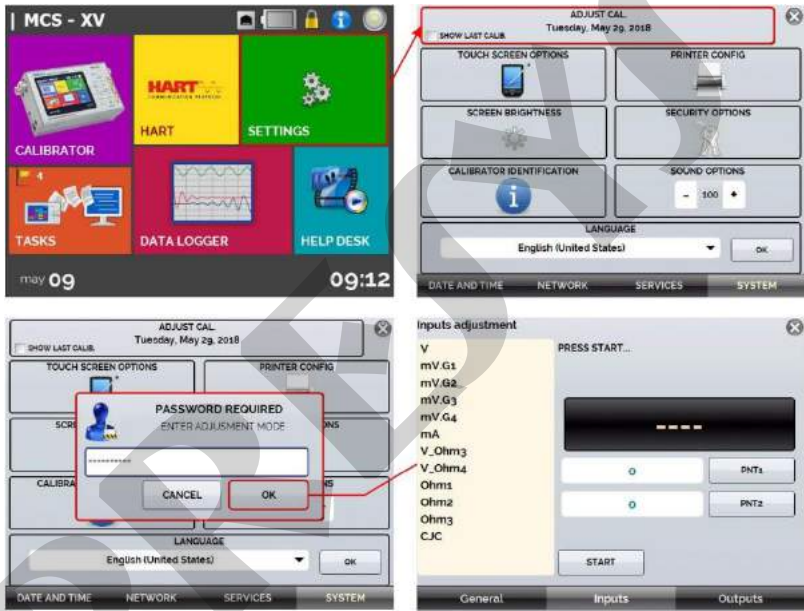

Fig. 85 – Adjust Options



IMPORTANT: Note that the thermocouples are only adjusted after the mV and cold junction (CJC) adjustments have been made. Only in the case of OHM or RTD is it necessary to perform the mV adjustment first.

4.1. Inputs Adjustment

4.1.1. V, mV, and mA Inputs

In the Inputs tab, select one of the inputs to perform the adjustment. Press the **START** button and then, in the blank field, enter the value corresponding to the point. Also notice that the screen presents the requested points to help make the input adjustment more intuitive.

After applying the signal, record the values at the 1st and 2nd calibration points (PNT1 and PNT2).

V Input	PNT1 – Adjust Value	PNT2 – Adjust Value
Single range	0,0000 V	11,0000 V

mV Input	PNT1 – Adjust Value	PNT2 – Adjust Value
G_4	0,000 mV	70,000 mV
G_3	0,000 mV	120,000 mV
G_2	0,000 mV	600,00 mV
G_1	600,00 mV	2400,00 mV

mA Input	PNT1 – Adjust Value	PNT2 – Adjust Value
Single range	0,0000 mA	20,0000 mA

The image below shows the mA adjustment process, use it as an example for the other inputs.

125

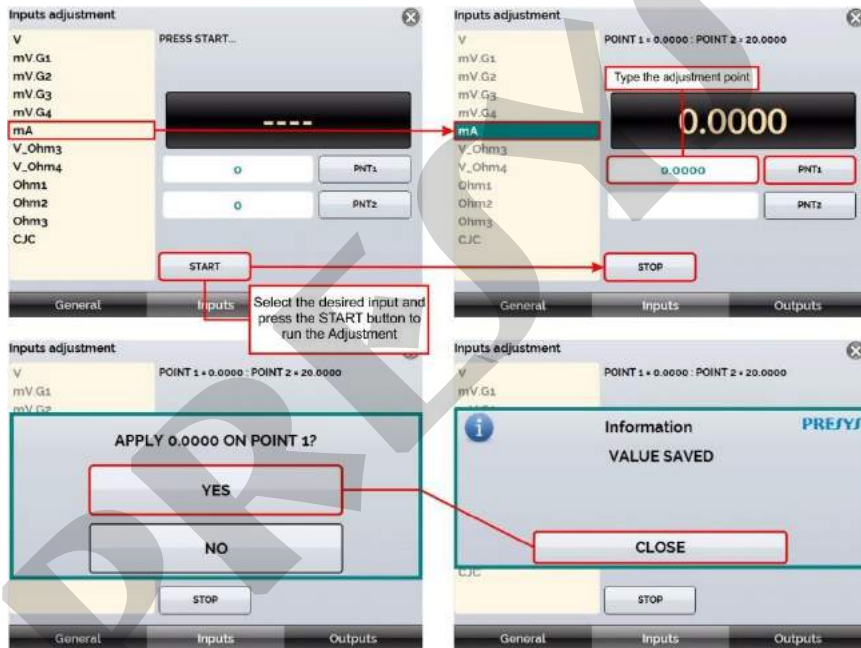

Fig. 86 – mA input adjustment

4.1.2. OHMS Input

The Ω input adjustment is done in two steps:

Step 1: mV Signal Application

For the adjustment below, short-circuit the RTD3(+) and RTD4(+) terminals.

mV Signal	Terminals	PNT1	PNT2
V_OHM3	RTD3(+) e GND IN (-)	90,000 mV	120,000 mV
V_OHM4	RTD4(+) e GND IN (-)	90,000 mV	120,000 mV

Etapa 2: Resistance Application

Connect a decade or standard resistors to the **RTD1**, **RTD2**, **RTD3** and **RTD4** terminals (4-wire connection).

Resistors	PNT1	PNT2
OHM3	20,000 Ω	50,000 Ω
OHM2	100,000 Ω	500,000 Ω
OHM1	500,000 Ω	2000,000 Ω

4.1.3. CJC Adjustment

Measure the GND IN terminal's internal temperature and record at point 1.

Cold Junction	PNT1
CJC	32,03 °C (measured temperature)

4.2. Outputs Adjustment

The outputs (except for CJC and Probe) are adjusted in steps. For each STEP, the calibrator generates a signal to be measured that must be registered by the user during the adjustment process.

4.2.1. V, mV, and mA Outputs

For these output ranges the screen will display three buttons: **STEP1**, **STEP2**, and **STEP3**. Select **STEP1**. The generated signal should be measured by a standard and the value should be saved by pressing the **SAVE** button. Repeat the procedure for **STEP2** and **STEP3**.

4.2.2. OHM Output

Due to accuracy considerations, the resistance output must be measured by a standard using a 4-wire connection. The polarity of the wires is initially not important since the excitation current can flow in both directions - from terminal RTD1 to RTD2 or from terminal RTD2 to RTD1.

The adjustment should be made in both ranges: 400 (OHM-400) and 2500 (OHM-2500).

For these output ranges, the display shows the buttons: **STEP1**, **STEP2**, **STEP3**, and **STEP4**. Select **STEP1**. The generated signal should be measured by a standard, and the value should be saved by pressing the **SAVE** button.

Repeat the procedure for **STEP2** and **STEP3**. Change the leads order connected to the **RTD1** terminal with those connected to the **RTD2** terminal and select **STEP4**. Measure the generated signal and save the measured value by default.

4.2.3. Probe Adjustment

First, identify the connector pins for the Probe according to the figure below.

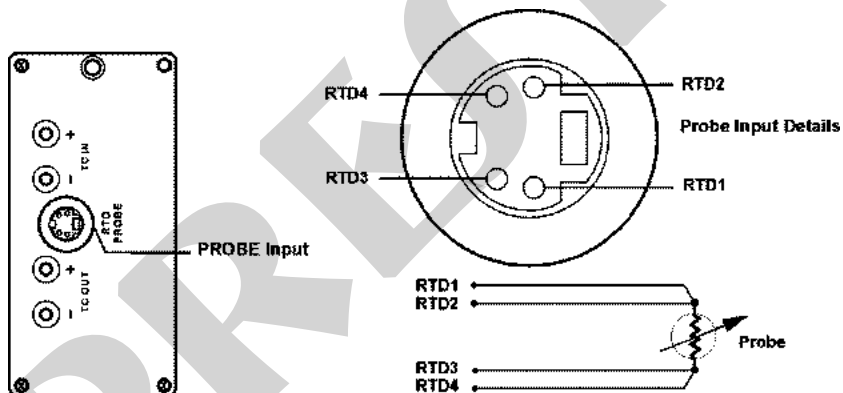

Fig. 87 – Probe Input Connection

The PROBE adjustment is performed in two steps:

Step 1: mV Signal Application :

mV Signal	Terminals	Terminals	PNT1	PNT2
V_2	RTD2(+)*	GND OUT (-)	70,000mV	120,000 mV
V_1	RTD2(+)*	GND OUT (-)	120,000mV	600,00 mV

(*) RTD2, for the PROBE setting, the reference is given by the terminals represented in **Fig. 86**.

Step 2: Standard Resistors Application

Connect a decade of resistance or standard resistors to the probe connector, in the RTD1, RTD2, RTD3, and RTD4 positions.

Resistors	PNT1	PNT2
R_2	20,000 Ω	50,000 Ω
R_1	100,000 Ω	500,000 Ω

Step 3: CJC Adjustment (Cold Junction Compensation)

The output cold junction adjustment is similar to the CJC input adjustment, but the temperature measurement is performed at the GND OUT terminal.

5. PRESSURE SENSOR INSTALLATION AND ADJUSTMENT

The MCS-XV calibrator allows the installation of new pressure sensors, as well as the adjustment of the capsules already installed. To perform the operations described in this section, please observe the recommendations and warnings.



ATTENTION! Only perform the procedures described in this section after fully understanding the information provided in this section. Failure to follow the warnings and information contained in these instructions may result in damage to the calibrator.



ATTENTION! Presys Instruments and Systems is not responsible for any damage caused to the MCS-XV due to non-compliance with the information provided.



ATTENTION: We recommend the use of standards with an accuracy three or four times superior to the technical specifications of this calibrator, as well as the execution of the adjustment in an environment where temperature and humidity are the closest possible to the laboratory characteristics, being: temperature of 23 ± 2 °C and controlled humidity close to $55 \pm 20\%$.



ATTENTION: For absolute, gauge, and vacuum pressure sensors, perform the adjustment in at least 6 POINTS throughout the range. For low-pressure and/or differential sensors, adjust by at least 11 POINTS.



IMPORTANT: In some cases, the value entered the calibrator will not be saved on the first confirmation (button pressed), this condition can be easily noticed because the display indicates different values in relation to the point entered. In these occasions, perform the point saving operation a few more times using the PNT key. This condition repeats itself for other inputs.

5.1. Installation

To install a new sensor on the MCS-XV, **turn off the calibrator** and remove the screws corresponding to the side where the sensor will be installed (C1 and C4 - right side / C2 and C3 - left side).

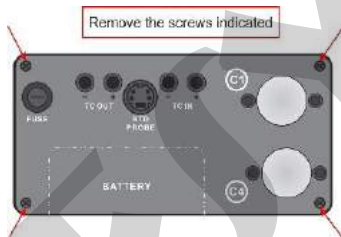

Fig. 88 – Screws indication

Then gently pull the cover off.



Fig. 89 – Cover Removal

Inside the calibrator, there is a connector available for each uninstalled capsule. Check its location and connect the capsule to the calibrator. If necessary, disconnect the fuse holder from the mA input for easy access when installing on the right side of the calibrator (slots for C1 and C2 available).



ATTENTION: Pay attention to the polarity between the sensor and the calibrator connectors. A white stripe indicates the correct polarity.



IMPORTANT: It is not necessary to perform any pressure or voltage adjustment procedures on the inserted sensor, you only need to set up the capsule information and parameters.

After the connection between the sensor and the calibrator, fix it in the housing of the equipment through the two screws that come with it.

5.2 Parameters Configuration

5.2.1. Sensor Information

In the Main Menu, press **SETTINGS** and then select the **SYSTEM** tab. In the top corner of the screen, press the **ADJUST CAL.** field. A pop-up will appear prompting you for a password, so type **9875** and press **ENTER**, then **OK**.

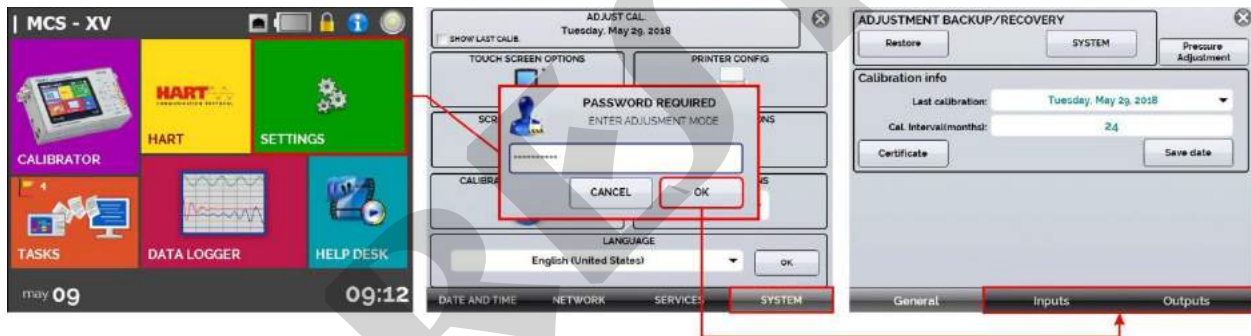

Fig. 90 – Adjust Menu Access

In the next window, press the Pressure Adjustment button. Then the **PRESSURE SETTINGS** screen will open, access the item **PARAMETERS CONFIGURATION**.

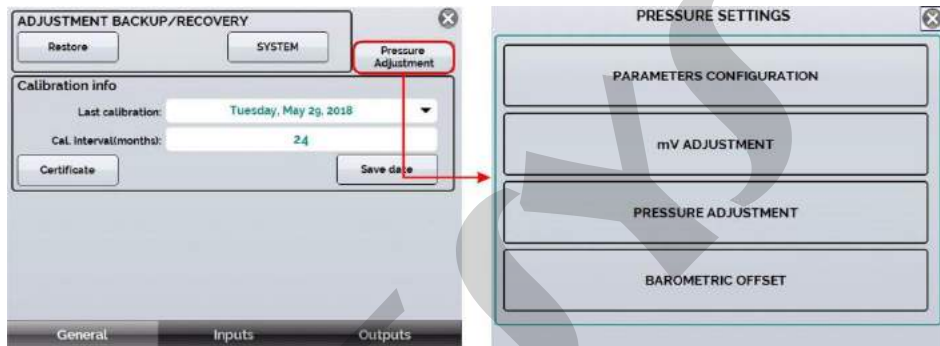

Fig. 91 – Accessing the parameters configuration

Right in the **CAP. INFO** tab it is possible to change or enter new data for a determined sensor. To change the information of the newly installed sensor, select its position (if C1, C2, C3 or C4).

Press the **EDIT** button to change the entered fields (serial number, scale start and scale end). After you finish editing the values, press **ENTER** to save.



IMPORTANT: If a barometric pressure sensor is installed in slot C4, mark the checkbox.

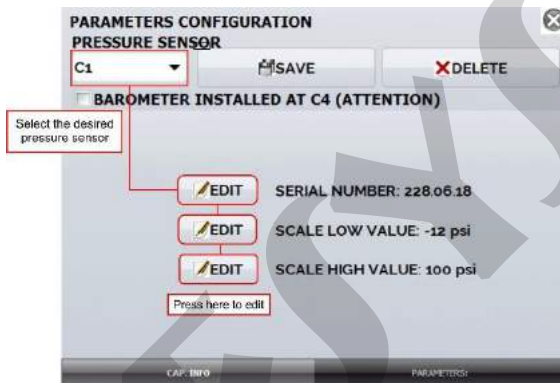

Fig. 92 – Changing information

Through the **PARAMETERS** tab the pressure sensors parameterization files are installed. Before starting this procedure, make sure that the parameters file (.cap extension) is duly stored in the calibrator memory in a folder named **PARAMETERS**.



IMPORTANT: The .cap file should be sent together with the purchased capsule. If you have not received it, please contact one of our representatives' sales.

In the **PRESSURE SENSOR** drop-down list, select the pressure sensor to perform the parameters installation. Then, in the **FILE INSTALLED** drop-down list, select the corresponding file. In the right corner of the screen, you should see the capsule actuation curve parameters, press **SAVE** to save the data or **DELETE** to remove it.

When the **SAVE** button is pressed, a confirmation pop-up will be displayed. Press **YES** to continue and **NO** to cancel the operation.

5.2.2. mV Adjustment

To perform the mV adjustment of a pressure sensor, use a connection jig as indicated in the picture below. Connect the jig to the sensor connector observing polarity.



Fig. 93 – Adjustment Jig

Then connect the jig terminals to a standard signal generator and a multimeter.



IMPORTANT: The standard electrical signal generator to be used in this adjustment process must have an accuracy of three or four times the accuracy described in the technical specifications of this calibrator.



ATTENTION: Do not insert any voltage signal to the pressure sensor before accessing the adjustment menu.

Access the **PRESSURE SETTINGS** and press the **mV ADJUSTMENT** button. On the next screen, select G2 in the GAIN field and press the START button. Follow the steps below to perform the adjustment:

- Note the **SAVED POINT** field, this field indicates which signal in mV should be inserted into the pressure capsule;
- Select **Point 1** from the drop-down list. Note that in the case of the 0.000 mV point it is possible to short-circuit the terminals of the Adjustment Jig;
- Press **ADJUST POINT** to enter the required point;



IMPORTANT: Make sure to generate the requested signal through your standard and monitor that the value is correct using a high accuracy multimeter.

- Repeat the point adjustment for at least two times to ensure that the point value will be saved correctly;
- Go to the **POINT** drop-down list and select Point 2;
- Repeat all the above steps until you have finished Point 2.
- After finishing, in the GAIN drop-down list, select G1 and adjust the required points in Point 1 and Point 2 and press the STOP button.

5.2.3. Pressure Adjustment



ATTENTION: For absolute, gauge, and vacuum pressure sensors, make the adjustment at a minimum of 6 (six) POINTS across the range. For low pressure and/or differential sensors, make the adjustment at least 11 (eleven) POINTS.



IMPORTANT: We recommend the application of pressure close or equivalent to the full scale of the adsensorsbeing adjusted for at least 5 (five) minutes before performing the procedure.

Pressure adjustment is performed by the calibrator in psi, so be sure to use the same engineering unit in your pressure standard.

In the **PRESSURE SETTING CENTER**, select the **PRESSURE ADJUST** option and on the next screen select from the **PRESSURE SENSOR** drop-down menu which sensor will be adjusted (choose among C1, C2, C3 and C4). Note that only the installed sensors will be shown in the list.

- Press the **START** button and observe the **SAVED POINT** field to identify each pressure value to be entered.

IMPORTANT: For the 0.0000 psi point, keep the sensor open to the atmosphere.

- Press the **SAVE** button at least twice to make sure that the current point will be saved;
- From the **POINT** pull-down menu, select the next point to be adjusted and repeat the steps above, making sure that the values entered are correct and waiting at least one minute before starting the point adjustment;
- After finishing the adjustment of the current sensor, press the **STOP** button and go to the **PRESSURE SENSOR** drop-down menu again to select the next sensor (if any);
- Repeat these steps until all sensors are adjusted.

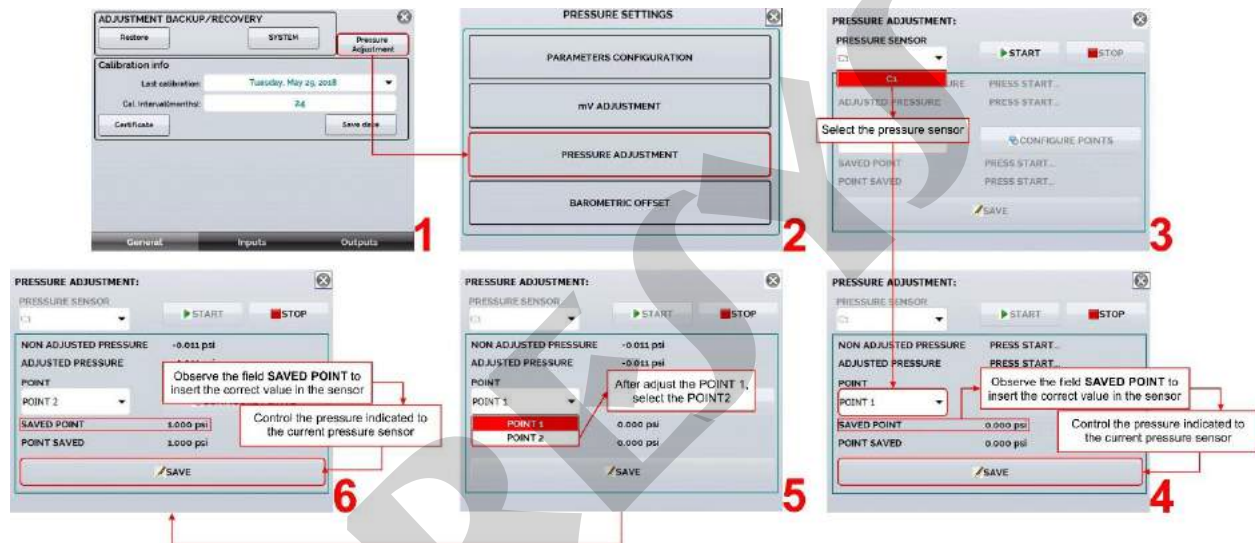

Fig. 94 – Pressure Adjustment

6. MAINTENANCE



ATTENTION: With the exception of battery and power input protection fuse replacement procedures, this equipment should not, under any circumstances, be manipulated for the purpose of performing any type of maintenance. Failure to comply with this information will result in the total loss of the warranty.



IMPORTANT: If a defect, malfunction, loss of calibration for no apparent reason or any other type of condition that prevents the use of this equipment according to the specifications described in this Technical Manual is verified, call the Technical Assistance service and request more information.

6.1. Battery Replacement (Only for portable MCS-XV)

To change the battery in the MCS-XV, proceed as follows:

- Loosen the battery cover screws - figure 95 A.
- Disconnect and pull out the battery-figures 95 B and C.
- Insert the new battery and connect it - figure 95 D.
- Close the cover - figure 95 E.



(A)



(B)



(C)



(D)



(E)

Fig. 95 – Battery Replacement

6.2. Battery Calibration (Only for portable MCS-XV)

If the battery of the portable (Field Service) calibrators is completely discharged or needs to be replaced, it is necessary to perform a charge indication recalibration procedure. To perform this process, proceed as follows:

Step 1

Be sure to fully charge the battery, respecting the minimum time of 4 (four) hours. With a full charge, the current usage indication is close to 0 (zero) mA. To check the battery information, from the Main Menu, press the battery icon and then a pop-up will be displayed.



Fig. 96 - Checking battery information

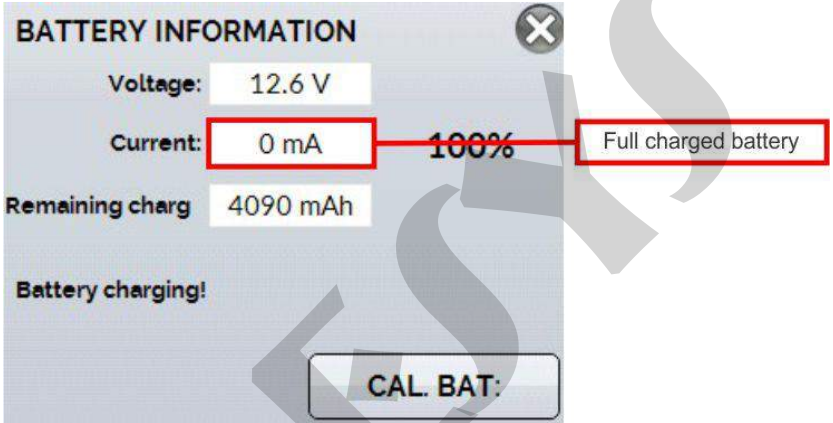

Fig. 97 - Full charged battery status

Step 2

Press the **CAL. BAT.** button and then, insert in the required field the access password **285**. Press **YES** to confirm and a confirmation pop-up will be displayed.

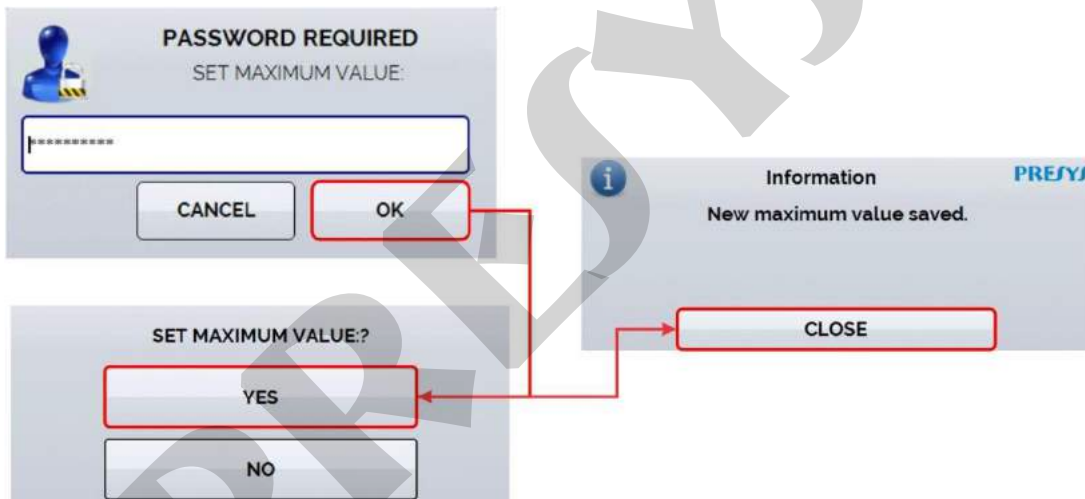

Fig. 98 – Calibrating the battery

Step 3

Remove the battery charger and observe if the battery remaining percentage is reduced and the indicated power current becomes negative.

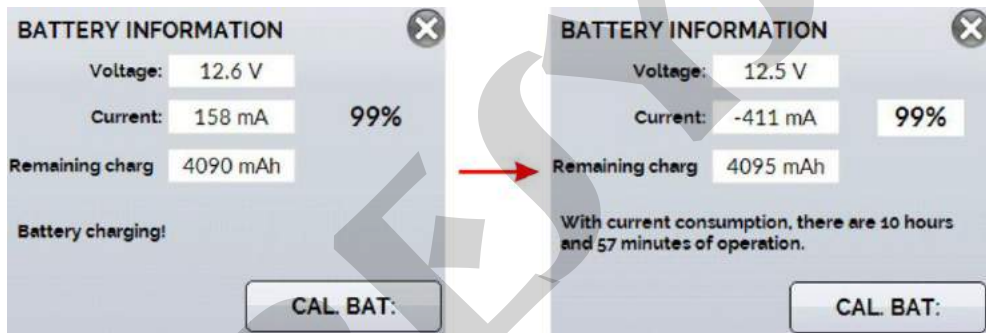

Fig. 99 – Battery usage

6.3. Replacement of the Current Input Fuse

To replace the MCS-XV current fuse, proceed as follows:

- Turn the fuse holder counterclockwise (**Fig. 100 A**). Try to use a plastic tool to do not damage the fuse holder.
- The fuse holder will be loose – **Fig. 100 B**.
- Pull the fuse holder and remove the fuse – **Fig. 100 C**.
- Place the spare fuse, which is in the bag for transporting the MCS-XV.



(A)



(B)



(C)

Fig. 100 – Current input fuse replacement

7. PRESSURE UNITS CONVERSION

psi	bar	mbar	MPa	kPa
1	0.06894757	68.94757	0.006894757	6.894757

psi	hPa	Pa	atm	at
1	68.94757	6894.757	0.06804605	0.07030696

psi	mmH ₂ O	mmH ₂ O@4°C	cmH ₂ O	cmH ₂ O@4°C
1	703.0696	703.0889	70.30696	70.30889

psi	mH ₂ O	mH ₂ O@4°C	ftH ₂ O	ftH ₂ O@4°C
1	0.7030696	0.7030889	2.306659	2.306726

psi	inH ₂ O	inH ₂ O@4°C	inH ₂ O@20°C	inH ₂ O@60°F
1	27.67990	27.68067	27.72977	27.70759

psi	torr	mmHg	mmHg@0°C	cmHg
1	51.71500	51.71500	51.71507	5.171500

psi	cmHg@0°C	inHg	inHg@0°C	inHg@60°F
1	5.171507	2.036024	2.036026	2.041772

psi	gf/cm ²	kgf/cm ²	kgf/m ²	
1	70.30696	0.07030696	703.0696	

Reference: Guide for the Use of the International System of Units (SI) – NIST Special publication 811 – 2008 Edition.

PRESYS

PRESYS

| Instruments Inc.
www.presys.com.br