

# PRESYS®



## Calibrator for Infrared Thermometer T-1200PIR

### Technical Manual



## WARNING!

Avoid electric shock risk on touching the equipment:

- Use only suitable power cable with earth connection;
  - Never power the equipment to the mains socket with no earth connection.
- 



## WARNING!

High voltage is present inside these equipments. It can cause great damages and injuries.

Do not make any repair service inside the equipment without removing the plug from the supply.

---



## WARNING!

Much electromagnetic noise can cause instability to the equipment.

The equipment is provided with electromagnetic interference filters that protect not only the mains but also the equipment itself against noise. These filters have no function if the unit is not earthed properly.

---



## WARNING!

High temperatures are achieved in these equipments.

Risk of fire and explosion are present in case safety measures are not taken. Sign by means of warnings the hazardous areas at high temperatures.

Do not obstruct any air-vent to avoid risk of fire in the equipment.

---



## WARNING!

Do not operate the instrument in excessively wet, oily, dusty or dirty environments.

Do not use sharp or pointed objects in the blackbody target.

Do not use abrasive materials or cleaning products on the blackbody target. These products may change the instrument properties.

Do not touch the blackbody target, skin salts and oils may damage the material properties.

---



## WARNING!

The instruments described in this technical manual are equipment for use in specialized technical area.

The user is responsible for configuration and selection of values of the parameters of the instruments.

The manufacturer warns against the risk of incidents with injuries to both persons and property, resulting from the incorrect use of the instrument.

---

## Disposal calibrator:



### NO HOUSEHOLD WASTE!

The calibrator of the series T Calibrator consist of various different materials. It must not be disposed of with household waste.

---

The warranty conditions are available in our sites:

**[www.presys.com.br/warranty](http://www.presys.com.br/warranty)**

## Table of Contents

<b>1.0 - Introduction .....</b>	<b>1</b>
1.1 - Technical Specifications .....	2
1.2 - Order Code .....	3
1.3 - Accessories .....	4
1.4 - Instructions for the use of Black Body Insert .....	4
<b>2.0 - T-1200PIR Calibrator Operating.....</b>	<b>6</b>
2.1 - Input Connections Diagram.....	8
2.2 - CONF Menu.....	9
2.3 - Manual Operating Mode .....	12
2.4 - Programmable Operating Mode .....	13
2.5 - Automatic Operating Mode .....	14
<b>3.0 - Usage Recommendations.....</b>	<b>16</b>
<b>4.0 - Safety Instructions .....</b>	<b>16</b>
<b>5.0 - Calibrator Warning Messages .....</b>	<b>17</b>
<b>6.0 - PID Control Parameters .....</b>	<b>17</b>
<b>7.0 - Calibration.....</b>	<b>18</b>
7.1 - Input Calibration.....	19
7.2 - Probe Calibration .....	20
<b>8.0 - Maintenance.....</b>	<b>20</b>
8.1 - Instructions for Hardware .....	20

## 1.0 - Introduction



**T-1200PIR**

The Calibrator for Infrared Thermometer T-1200PIR generates temperature values in order to enable the calibration of infrared thermometers. The temperatures generated have high accuracy, in an area of uniform temperature and emissivity.

This calibrator also has input for thermocouples and resistance thermometers, as well as current meter function. The T-1200PIR generates temperature from 50 to 1200 °C.

- Has input for thermocouples, RTDs and thermostats reading.
- The use of external standard thermometer is not required\*.
- Carries out completely automatic calibrations with or without the use of a computer.
- Accuracy of 3 °C, 0.2 °C stability and 0.1 °C resolution.
- Documenting capabilities: communication with computer and ISOPLAN Calibration Software.
- Portable and compact, has strap for easy transport.

*\* For higher performances, it is possible to make use of an external thermocouple sensor type "N" connected to its own input.*

It has extensive programming capabilities, where the calibrator is programmed to generate pre-set temperature.

Compatible with automatic calibration and documenting software, with application of ISOPLAN software on PC / Windows platform, using the serial port for connection between the PC and the calibrator that communicate via RS-232 or RS-485. ISOPLAN software can register thermometers and factory instruments, generate work orders, produce and print calibration certificates and reports, that is, all the information of power is brought into the environment of calibrations.

T-1200PIR has also many other features, such as:

- The electric signal calibrator is independent from the temperature control function.
- Internal buzzer beeps when the temperature reaches the desired value.
- Numeric keypad that eases the operation and configuration of the calibrator.
- OLED graphic display for presenting large digits.
- Thermo-element reading scaled to ITS-90 or IPTS-68.
- Internal regulated 24 Vdc power supply for 2-wire transmitters.
- Internal rechargeable battery and battery charger included in the electric signal calibrator.
- Independent circuitry for over temperature protection and safety.

The calibrator operates with Nickel-Metal Hydride (Ni-MH) batteries.

### 1.1 - Technical Specifications

<b>T-1200PIR</b>	
<b>Operating Range</b> ambient temperature: 23 °C	50 °C to 1200 °C
<b>Display Accuracy</b> internal reference with (external thermometer)	± 2.2 °C ± 0.75 °C
<b>Resolution:</b>	± 0.1 °C
<b>Stability:</b>	± 0.2 °C
<b>Target Size:</b>	20 mm
<b>Target Emissivity (ε):</b>	0.99
<b>Heating Time:</b>	45 minutes (100 °C to 1200 °C)
<b>Cooling Time:</b>	5 hours (1200 °C to 200 °C)
<b>Weight:</b>	10.4 kg
<b>Power Supply:</b>	115 Vac or 230 Vac 50/60 Hz
<b>Units / Temperature Scales:</b>	°C or °F / IPTS-68 or ITS-90, user selectable
<b>Display:</b>	Graphic vacuum fluorescent with contrast adjustment
<b>Dimensions (H/W/D):</b>	205 x 399 x 303 mm

\*according to the order code

**1.1.1 - Input Technical Specifications**

Input Ranges		Resolution	Accuracy	Remarks
millivolt	-150 to 150 mV	0.001 mV	± 0.01 % FS*	R <sub>input</sub> > 10 M Ω auto-ranging
	-500 to -150 mV	0.01 mV	± 0.02 % FS	
	150 to 2450 mV	0.01 mV	± 0.02 % FS	
mA	-5 to 24.5 mA	0.0001 mA	± 0.02 % FS	R <sub>input</sub> < 160 Ω
	Resistance			
	0 to 400 Ω	0.01 Ω	± 0.01 % FS	excitation current 0.85mA
	400 to 2500 Ω	0.01 Ω	± 0.03 % FS	
Pt-100	-200 to 850 °C / -328 to 1562 °F	0.01 °C / 0.01 °F	± 0.1 °C / ± 0.2 °F	IEC-60751
Pt-1000	-200 to 400 °C / -328 to 752 °F	0.1 °C / 0.1 °F	± 0.1 °C / ± 0.2 °F	IEC-60751
TC-B	50 to 250 °C / 122 to 482 °F	0.1 °C / 0.1 °F	± 2.5 °C / ± 5.0 °F	IEC-60584
	250 to 500 °C / 482 to 932 °F	0.1 °C / 0.1 °F	± 1.5 °C / ± 3.0 °F	
	500 to 1200 °C / 932 to 2192 °F	0.1 °C / 0.1 °F	± 1.0 °C / ± 2.0 °F	
	1200 to 1820 °C / 2192 to 3308 °F	0.1 °C / 0.1 °F	± 0.7 °C / ± 1.4 °F	
TC-J	-210 to 1200 °C / -346 to 2192 °F	0.1 °C / 0.1 °F	± 0.2 °C / ± 0.4 °F	IEC-60584
TC-K	-270 to -150 °C / -454 to -238 °F	0.1 °C / 0.1 °F	± 0.5 °C / ± 1.0 °F	IEC-60584
	-150 to 1370 °C / -238 to 2498 °F	0.1 °C / 0.1 °F	± 0.2 °C / ± 0.4 °F	
TC-N	-260 to -200 °C / -436 to -328 °F	0.1 °C / 0.1 °F	± 1.0 °C / ± 2.0 °F	IEC-60584
	-200 to -20 °C / -328 to -4 °F	0.1 °C / 0.1 °F	± 0.4 °C / ± 0.8 °F	
	-20 to 1300 °C / -4 to 2372 °F	0.1 °C / 0.1 °F	± 0.2 °C / ± 0.4 °F	
TC-R	-50 to 300 °C / -58 to -572 °F	0.1 °C / 0.1 °F	± 1.0 °C / ± 2.0 °F	IEC-60584
	300 to 1760 °C / 572 to 3200 °F	0.1 °C / 0.1 °F	± 0.7 °C / ± 1.4 °F	
TC-S	-50 to 300 °C / -58 to -572 °F	0.1 °C / 0.1 °F	± 1.0 °C / ± 2.0 °F	IEC-60584
	300 to 1760 °C / 572 to 3200 °F	0.1 °C / 0.1 °F	± 0.7 °C / ± 1.4 °F	

\* FS = Full Scale

**1.2 - Order Code**

T-1200PIR -

**Power Supply**

1 - 115 Vac

2 - 230 Vac

### 1.3 - Accessories

- **Communication Interface:**

Description	Order Code
RS-232 - DB-9F Connector (COM1)	06.02.0002-00
RS-232 - DB-25F Connector (COM2)	06.02.0004-00
RS-485	06.02.0006-00

**Serial Communication:** Modbus® RTU Protocol (RS-232/ RS-485).

**Included Items:** carrying case, straps, black body insert, test leads, insulation, manual and power cord.

**Optional Accessories:** Communication Interface - Order Code: 06.02.0002-00.

**Spare Accessories:** Thermocouple TC-N - Order Code: 01.22.0088-00

### 1.4 - Instructions for the use of Black Body Insert

Identify the following parts and proceed to the mounting as explained:

- Cylindrical Thermal insulator – Mounted in the lower part of the pit of the furnace.
- Metallic insert type black body cavity – Must be introduced in the pit joined with a thermocouple type N mounted laterally.



Careful when introducing the thermocouple in the cavity to not force the fragile ceramic wall pit.

- Ring-shaped cylindrical Insulator - mounted on top of the pit of the furnace



Note that the position of the slit of insulation should match the type N thermocouple sheath laterally.

- Connect the terminals of the thermocouple type N to the auxiliary input side of the furnace T-1200PIR and set the reading of the IN input to N type thermocouple.

The combination constitutes an excellent mounted cavity blackbody with emissivity of 0.99 for a wave-length from 1 µm to 14 µm.

Align the pyrometer to be calibrated with a black body cavity in the furnace in a horizontal position.

Observe the distance of the pyrometer to be calibrated against the background of the black body cavity and the size of the actual target (Ø 20 mm) as specified in the technical manual optical pyrometer.

Remember that the area targeted by the pyrometer to be calibrated must be less than or equal to the effective target spot size of the black body in order to not introduce measurement errors.

Use the certificate of calibration of the thermocouple type N to correct the readings from the IN input of the calibrator and comparing the reading of the pyrometer. Use a cable to short circuit the TC sensor sheath with the GND (mV (-)) in order to prevent noise interference.

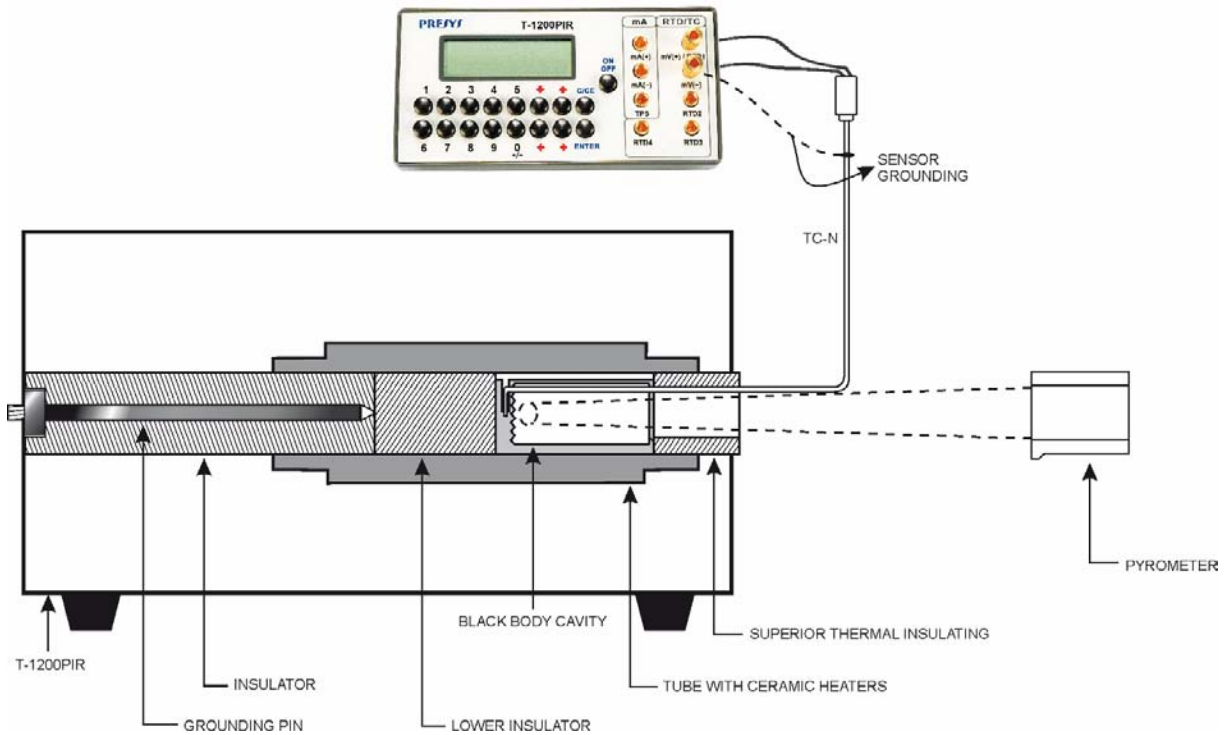

**SCHEMATIC VIEW FOR MOUNTING OF THE BLACK BODY CAVITY**

## 2.0 - T-1200PIR Calibrator Operating

The T-1200PIR calibrator keeps controlled the temperature of the black body cavity and is suitable for calibration of infrared thermometers.

The calibrator has 3 operating modes:

- *Manual Mode* to select the temperature straight from the keypad
- *Programmable Mode*: 6 different programs with 11 temperature set point values. The cavity temperature is selected among the programmed values by the keys  $\uparrow$  and  $\downarrow$ . The *Programmable Mode with Timer* scans automatically the temperature set points.
- *Automatic Mode* calibration is performed in an automatic way by the calibrator: the schedule and the calibration results, besides the thermo-element readings are stored in the calibrator memory. For pyrometers with local indication, the reading is entered manually and for pyrometers with response in mA, mV or thermocouple, reading is performed automatically by the input of the calibrator.

When powered on (**ON/OFF** key), the calibrator goes through a self-test routine and shows the last calibration date and the value of the battery voltage. The battery voltage is constantly monitored and the low battery warning is provided. After the self-test is completed, the display shows the starting menu. The initial set point is 50.00 °C.

$\Rightarrow$ IN	EXEC	
CONF	CAL	COM

By means of keys  $\uparrow$ ,  $\downarrow$ ,  $\leftarrow$  and  $\Rightarrow$ , choose the menu options and press **ENTER**.

**IN**: selection of the calibrator signal input. Choose among mV, Ohms, thermocouples, RTDs, mA, switch or none. More details in item 2.1 - *IN Menu*.

**EXEC**: The calibrator enters the manual or programmable operating mode.

**CONF**: Accesses the calibrator configuration options. More details in item 2.2 - *CONF Menu*.

**CAL**: This option accesses the T-1200PIR calibrator adjust functions, protected by password. More details in section 7 - *Calibration*.

**COM**: Accesses the automatic calibration parameters. It is possible to perform a calibration without a computer or using it (via ISOPLAN software). More details in item 2.5 - *Automatic Operating Mode*.

## 2.1 - IN Menu

⇒ mV	OHM	TC	
RTD	mA	SW	NO

**mV, mA, SW:** selects millivolt, milliampere or switch input, respectively.

**OHM:** selects ohms input. Following, choose from the menu the wiring in 2, 3 or 4-wire.

⇒ 2-WIRE	3-WIRE
4-WIRE	

**TC:** selects thermocouple input. Choose among the **B, J, K, N, R** and **S** types. In the next menu, the internal or manual cold junction compensation is chosen.

⇒ INTERNAL
MANUAL

If the internal compensation is selected, the cold junction temperature value is displayed by the calibrator. If the **MANUAL** option is selected, the cold junction must be supplied by the operator. After confirming the value, by pressing **ENTER**, the calibrator goes back to the operating mode.

**RTD:** Selects the type of RTD (Resistance Thermometer) used. Choose from **PT100, NI100, CU10** and **PT1000** types. Choose also if the wiring is 2, 3 or 4-wire.

**NO:** Disables reading of external signal.

Selecting one of the options above, the calibrator goes straight to the manual operating mode, with no need to select the **EXEC** option.

## 2.1 - Input Connections Diagram

Millivolts

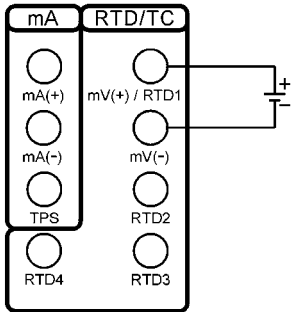

Thermocouple (TC)

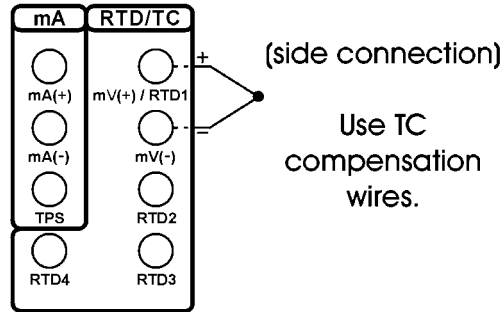

Ohm / RTD  
(2-wire)

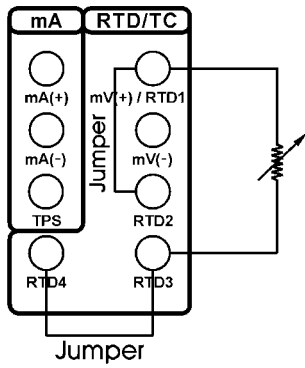

Ohm / RTD  
(3-wire)

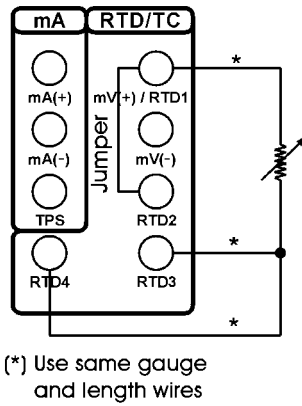

Ohm / RTD  
(4-wire)

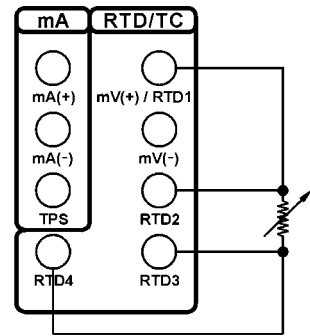

mA

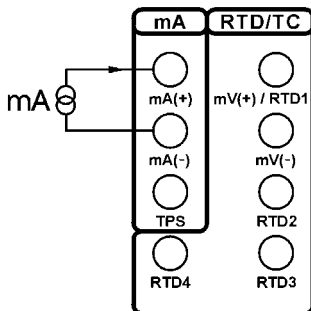

mA with power supply

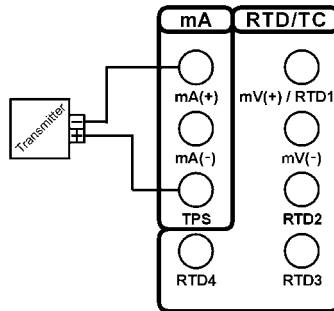

Switch (SW)

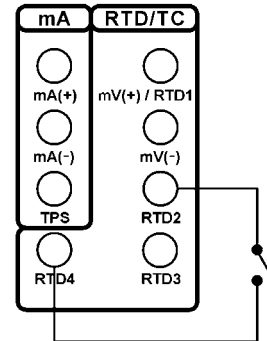

## 2.2 - CONF Menu

⇒ CF	PRG	MEM	DSP
SC	BT	DT	BZ
	TU		

**CF:** Selects the temperature unit between °C and °F. The ITS-90 or IPTS-68 temperature scales are selected for both the thermo-element and for the black body cavity temperature reading/control.

⇒ °C-90	°F-90
°C-68	°F-68

**DSP:** This option sets the OLED display contrast. Use the keys ↑ and ↓ until you get a better contrast and finish the operation by pressing the key ENTER.

**BT:** Shows the battery or the battery charger voltage value if the black body cavity is turned off or on, respectively.

Battery level	Battery state	Display
4.0 to 7.0 V	normal	-----
< 4.0 V	low	LOW BATTERY

**DT:** Updates the date and time of the calibrator. Thus, when the calibrator performs a calibration in the automatic mode via ISOPLAN, all data are registered together with date and time of occurrence. Every time the calibrator is powered off, the internal clock does not continue to be updated. However, the ISOPLAN software can automatically update the calibrator date and time with the computer internal clock. Otherwise, use keys ↑ and ↓ to change the field that blinks and the keys ⇒ and ⇐ to go to another field. The key **ENTER** confirms the last selection.

**BZ:** Menu that configures the piezoelectric buzzer.

⇒ NO	YES	ENDCAL
------	-----	--------

**NO:** Disables the buzzer.

**YES:** The buzzer beeps when the cavity reaches the set point and stabilizes.

**ENDCAL:** The buzzer beeps only at the end of a calibration in the automatic operating mode

**TU:** Menu that configures the PID control parameters for the heating side. More details in section 6 - *PID Control Parameters*.



**K:** Proportional gain

**I:** Integral gain

**D:** Derivative gain

**FACT:** Restore the control parameters to the factory values.

**PRG:** Menu that programs the calibrator.



**DEC\_IN:** Selects the number of decimals of the thermo-element reading. The default value depends on the input signal.

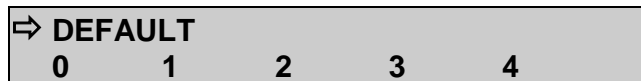

**DEC\_PRB:** Selects the number of decimals of the cavity temperature and the set point value. The default number is 1.



**SET POINT:** Enables the calibrator *Programmable Operating Mode*, and allows the configuration of programmed values. The selected program is indicated by the selection arrow. Choose one of the **6** temperature programs or **NO** to disable this *Programmable Mode*.

Select any of the 6 programs and confirm with the key **ENTER**. Following, it is shown the menu of temperature set point configuration.

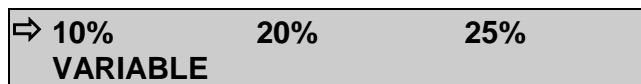

Change the configuration to STEPS of **10%**, **20%**, **25%**, **VARIABLE** or press **C/CE** to maintain the configuration already stored in memory. The temperature range of the program must be configured through the values in **SET POINT HIGH** and **SET POINT LOW** in case of **10%**, **20%** or **25%** fixed steps of the range. The option **VARIABLE** allows the user to define from 2 to 11 values of temperature set point, not necessarily in ascending order.

To verify the step values of a program, select the **VARIABLE** option and confirm the values shown in the display with the key **ENTER**. The **10%**, **20%** and **25%**

options change the number of steps automatically and recalculate the values according to **SET POINT HIGH** and **SET POINT LOW**.

**SC**: This function scales the input reading of pyrometric transmitters. The scaling is very useful in temperature transmitter calibration, for instance, because it displays the current temperature and the transmitter reading in the same unit. Thus, the error can be verified directly in °C or °F. Select the option **SC** and press **ENTER**. If no input is selected in **IN**, the calibrator will show the **SELECT INPUT FIRST** message. In this case, go to menu **IN** and select the input signal type.

The function **SC** will show **IN** or **NO**. Confirm **IN** to configure the scaling or **NO** to disable the **SC** function, with the key **ENTER**.

The scaling is performed via the **INPUT HIGH** and **INPUT LOW** parameters, corresponding to the maximum and minimum values of the calibrator signal input, in the engineering unit of this signal. Next, configure the **SCALE DEC (0-4)**, **SCALE HIGH** and **SCALE LOW** parameters according to the maximum and minimum values of the transmitter scale and the desired number of decimals. The scaled value is shown on the display with the **#** unit.

For example, temperature transmitter with 0 to 100 °C input and 4 to 20 mA output. The scaling with one decimal would be:

**INPUT HIGH**: 20.0000 mA

**INPUT LOW**: 4.0000 mA

**SCALE DEC (0-4)**: 1

**SCALE HIGH**: 100.0 #

**SCALE LOW**: 0.0 #

**MEM:** The T-1200PIR calibrators allow many special programs and functions that can be of frequent use. In situations like this, it would be useful to store the current configuration in memory in order to save time. Up to 8 configurations can be stored in memory.

Selecting the option **MEM**, it is possible to store the current configuration (**WRITE**), restore a previous stored configuration (**RECALL**) or erase the 8 configurations from memory (**CLEAR ALL**).

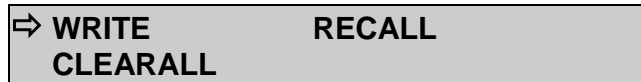

Selecting the option **WRITE** or **RECALL** will present a new menu with numbers 1 to 8, representing each one of the memory positions. Choose one of the positions and press **ENTER**. The writing operation (**WRITE**) can be made in an already used memory position. The calibrator confirms the overwriting confirmation with the message **OVERWRITE MEMORY?** The **CLEAR ALL** operation shows a confirming message **ARE YOU SURE?** In both cases, press **ENTER** to confirm the operation or **C/CE** to cancel.

### 2.3 - Manual Operating Mode

The display shows the selected temperature value of black body cavity and also the current cavity temperature or thermo-element temperature value.

There are 4 ways in which the information are shown, covering the calibrator input value (**IN**), the black body cavity temperature (**PROB**) and the temperature set point (**SET**). The key  $\leftarrow$  interchanges the display presentation way:

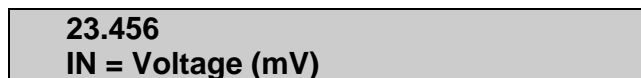
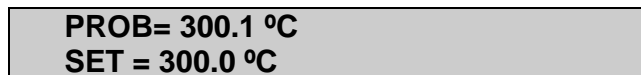
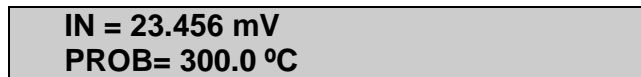

The black body temperature set point is selected directly by the keypad, even if the message **SET** is not being displayed. The numeric keypad enables the **SET** selection in any of the display presentation ways, to change the set point.

The set point value is increased by key  $\uparrow$  and decreased by key  $\downarrow$ . While the keys are kept pressed, the set point continues to be increased or decreased.

The key  $\Rightarrow$  does not have function in the manual operating mode of the T-1200PIR calibrators.

Internally, the set point changes at a limited rate to make possible a safer and more homogeneous heating of the internal ceramic tube. Besides, the PID parameters and algorithm were adjusted to assure a minimal stabilization time and overshoot.

## 2.4 - Programmable Operating Mode

Pre-configured programs can be loaded from the calibrator memory, enabling the programmable operating mode. The temperature programmed values of the cavity are used directly, with no need to enter the set point.

The display shows **STEPn** beside the cavity temperature set point value in the programmable mode. The number of the program is indicated by **n**. Using the keys  $\uparrow$  and  $\downarrow$ , the programmed values of temperature set point are changed. The numeric keypad continues available for manual selection of the black body cavity temperature in the same way of the manual operating mode.

The automatic scan over the programmed temperatures is implemented by defining the stabilization time of the thermo-element in the black body cavity.

The key  $\Rightarrow$  enables the automatic scan over the points. When pressed, the message **STEPn** gives place to **0s** and the calibrator waits for the stabilization time configured from 1 to 9 minutes, by the keys **1** to **9**. The automatic scan is disabled by pressing key  $\Rightarrow$  again.

A countdown of the stabilization time is only started when the cavity temperature reaches the programmed temperature and stabilizes within a range of approximately  $\pm 0.20$  °C. At this time the buzzer beeps, in case it is configured to **YES**.

## 2.5 - Automatic Operating Mode

The thermo-element calibration is performed in an automatic way by the T-1200PIR calibrator. The configuration, as well as the calibration verification is carried out by the calibrator itself. Also it is possible to use the ISOPLAN software and its work orders, like a CAC - Computer Aided Calibration.

The independent automatic calibration, without the use of ISOPLAN, is planned in the option **TAGMAN** from menu **COM**.

<b>TAG</b>	<b>EXEC</b>	<b>VERIF</b>
<b>ADDRESS</b>	⇒	<b>TAGMAN</b>

Before start programming, configure the signal that will be read by the calibrator in the menu **IN**. To calibrate pyrometers with local indication, for example, there is no electric signal to be read. In this case, option **IN** from the menu must be configured to **NO** and the calibrator will ask to enter the value indicated by the pyrometer, at the end of the stabilization time of each calibration point.

The data for an automatic calibration are:

- **TAG**: the pyrometer tag identification.
- **SP**: the black body cavity temperature reference values for the calibration (calibration points).
- **TOL**: the maximum tolerance for the pyrometer operation.
- **STB**: the stabilization time, in seconds, so that the pyrometer reading can be taken. This timer starts just after the cavity reaches and stabilizes at the set point temperature.
- **STR**: the calibration strategy of the programmed reference values. The available strategies are: ↑ (UP), ↓ (DOWN), ↑↓ (UP - DOWN), ↓↑ (DOWN - UP), ↑↓↑ (UP - DOWN - UP) and ↓↑↓ (DOWN - UP - DOWN).
- **RP**: the strategy number of repetitions.
- **RGI**: the pyrometer indication range.
- **RGO**: the operating temperature range that corresponds to the indication range above.

The automatic calibration begins when the option **EXEC** from menu **COM** is selected. All the operations are automatically performed by the T-1200PIR calibrator. The keypad does not work until the end of the calibration.

At the end of the stabilization time, the calibrator stores the pyrometer reading in memory and goes to the next point, in case some input signal has been previously configured in the menu **IN** and connected to the calibrator terminals.

The **CALIBRATION END** message appears on the display at the end of the automatic calibration. Press **ENTER** to confirm. The results can be verified in option **VERIF** from menu **COM**.

The first message in option **VERIF** informs the calibration result, with the number of points that have succeeded or not. Following, press **ENTER** to verify each one of the readings performed by the calibrator. The keys ⇌ and ⇐ interchange 2 screens: one that displays the cavity and thermo-element temperature value and the other displays a

message indicating the calibration point number and its state (**OK** or **FAIL**), besides the error value in %.

The option **TAG** from menu **COM** can present a list of up to 4 tags that have been downloaded or uploaded with ISOPLAN software. The key **ENTER** selects the tag to be calibrated from the tag list. The automatic calibration starts by the option **EXEC** from menu **COM** and the calibration data can be verified in option **VERIF**. To calibrate automatically not using the ISOPLAN, there is a reserved place for one manual tag. The selection of the manual tag is performed by confirming the option **TAGMAN** with the key **ENTER**.

The option **ADDRESS** selects the communication address of the T-1200PIR calibrator. The communication protocol used is ModBus - RTU, with no parity and baud rate of 9600. The calibrator communication with the computer can use RS-232 or RS-485, for network option, according to the communication interface used. In order to communicate with ISOPLAN software, configure **ADDRESS** to 1.

### 3.0 - Usage Recommendations

It is of great importance to know the instrument to be calibrated. Infrared thermometers have characteristics which must be met so that the observed results are correct, as setting of emissivity (if any), focal length and focus area, e.g. These data are easily obtained in the thermometer user manual and this observation is needed to prove the compatibility of thermometers with the calibrator.

To perform the readings, align the pyrometer with the black body cavity horizontally. Respect the distance from the pyrometer to be calibrated in relation to the black body cavity to the size of the actual cavity as pyrometer manual. Remember that the area focused by the pyrometer to be calibrated must be less than or equal to the black body cavity size in order to not introduce measurement errors.

The external sensor can be used to increase the accuracy of temperature indication.

### 4.0 - Safety Instructions

- Do not leave the place where the calibrator is on without identification and warnings.
- Before turning off the calibrator, return temperature black body cavity for values close to ambient temperature.

## 5.0 - Calibrator Warning Messages

Warning	Meaning	Procedure
RAM ERROR READ MANUAL	Problem in RAM memory	Turn the calibrator off and on. If the error persists, send the instrument to the factory
EEPROM ERROR READ MANUAL	Problem in EEPROM memory	Same as the previous item
LOW BATTERY	Level of battery voltage is low	Check the T-1200PIR calibrator power supply
UNDER / OVER	Input signal out of specifications or scaling range	See item 1.1.1 on Input Specifications
????.?°C	Input sensor is open	Check input connections and sensor

## 6.0 - PID Control Parameters

The T-1200PIR calibrators have a PID control algorithm to calculate the temperature control output.

The black body cavity stability and response time features are related to the PID parameters, explained below:

The **K** parameter (proportional gain) amplifies the error signal between the set point and the cavity temperature to establish the output signal. When this parameter is very high, the output reaction is very quick; however this can take the system into oscillation. Decreasing this parameter, the cavity would not be able to react quickly enough to external variations, giving the impression of a sudden out of control.

The **I** parameter (integral gain) is responsible for the integral action and it is the most important part in the set point control. While an error persists between the set point and the cavity temperature, the integral action will actuate on the output signal until the error is brought to zero.

The **D** parameter (derivative gain) is responsible for the derivative action that provides a quick response at the control output resulting from any rapt variation in the cavity temperature. It is used to eliminate oscillations. However, it can cause oscillations in the presence of much noise.

All temperature calibrators are tuned in factory and the parameters are close to the optimum ones. In case one wants to improve a specific feature of the calibrator (stabilization time or response time, for instance), make sure the alteration is made reasonably.

## 7.0 - Calibration



**ATTENTION:** To prevent potential damage to the instrument's calibration due to improper adjustments, the access password must be requested from your local distributor.

**Adjustment procedure access password:** To perform input or output adjustments, the owner of the calibrator must contact the local distributor, providing the equipment's **serial number** to receive the password that allows access to the adjustment.

**WARNING:** Enter the following options only after understanding them completely. Otherwise, it may be necessary to return the instrument to the factory for recalibration!

Select **CAL** option from the main menu and press the **ENTER** key. You should then enter the password (**PASSWORD**) to access the calibration menu.

The password functions as a protection to calibration ranges. After the password is entered, the menu displays the options:



You should then choose the input range (**IN**) as the output range (**OUT**) is not available for the user. **DATE** is an option which allows you to record the date on which the calibration was performed and once it has been filled in, it will be displayed every time the calibrator is turned on.

Options for **IN** calibration are:

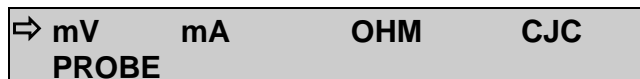

## 7.1 - Input Calibration

Select the corresponding mnemonic and apply the signals presented in the tables below.

When calibrating inputs, the display shows on the 2<sup>nd</sup> line the value measured by the calibrator and on the 1<sup>st</sup> line the same value is expressed as a percentage.

Note that the applied signals just need to be close to the values shown in the table.

Once the signal has been applied, store the values of the 1<sup>st</sup> and 2<sup>nd</sup> calibration points, by pressing keys 1 (1<sup>st</sup> point) and 2 (2<sup>nd</sup> point).

mV Input	1 <sup>st</sup> point	2 <sup>nd</sup> point
G4	0.000 mV	70.000 mV
G3	0.000 mV	120.000 mV
G2	0.000 mV	600.000 mV
G1	600.000 mV	2400.000 mV

mA Input	1 <sup>st</sup> point	2 <sup>nd</sup> point
Single range	0.0000 mA	20.0000 mA

Input calibration for  $\Omega$  is performed in two steps:

a) Application of mV signal:

For the calibration below, leave terminals RTD3 (+) and RTD4 (+) short-circuited.

mV Signal	Terminals	1 <sup>st</sup> point	2 <sup>nd</sup> point
V_OHM3	RTD3(+) and mV(-)	90.000 mV	120.000 mV
V_OHM4	RTD4(+) and mV(-)	90.000 mV	120.000 mV

b) Application of standard resistors:

Connect a decade box or standard resistors on terminals RTD1, RTD2, RTD3 and RTD4 (4-wire connection).

resistors	1 <sup>st</sup> point	2 <sup>nd</sup> point
OHM3	20.000 $\Omega$	50.000 $\Omega$
OHM2	100.000 $\Omega$	500.000 $\Omega$
OHM1	500.000 $\Omega$	2200.000 $\Omega$

The cold junction calibration (CJC) is performed measuring the mV (-) terminal temperature. Store only the 1<sup>st</sup> point.

Cold Junction	1 <sup>st</sup> point
CJC	32.03 °C

## 7.2 - Probe Calibration

The options of **CAL>PROBE** are:



**°C**: Adjust of the internal temperature sensor (internal Probe).

**RESTORE**: Restores the internal temperature sensor calibration parameters to the factory values.

To readjust the internal Probe it is necessary to compare the value indicated by the calibrator (Probe) and the temperature value from an external probe placed in an insert. The temperature of the external probe should have high accuracy and should be measured by a superthermometer (ST).

The option to adjust the internal sensor has seven points of adjustment. These points are recorded via keys 1 to 7.

Before starting the calibration (adjustment), record in these points the respective initial storing values, according to the table below.

Go to the manual operating mode (menu **EXEC**) and generate all the seven levels of temperature (set points from the table), writing down the value indicated by the superthermometer (ST). Now, go back to the option Calibration/ Probe / °C and record the values indicated by the superthermometer.

Set point of the temperature generated (°C)	Initial value to record (°C)	ST indication	New value to record	New indication of the ST	key
150	150.0	149.96	150.0	150.01	key 1
350	350.0	349.93	349.9	349.99	key 2
600	600.0	598.03	598.0	600.02	key 3
750	750.0	745.32	745.3	749.99	key 4
850	850.0	843.13	843.1	850.03	key 5
1000	1000.0	990.45	990.4	999.97	key 6
1100	1100.0	1087.11	1087.1	1100.05	key 7

## 8.0 - Maintenance

### 8.1 - Instructions for Hardware

There are no parts or components in the T-1200PIR temperature calibrators that can be repaired by the user. Only the 10 A fuse, placed within the socket on the rear can be replaced by the user.

The fuse may blow due to a voltage spike in the mains or a calibrator component fault. Replace the fuse once. If a second fuse blows again, it is because the fault is not that simple. Contact the Presys technical assistance or send the calibrator to the factory for repair.

