

PRESYS®



PSV Portable Test Station Technical Manual



ATTENTION!

Please read the following instructions before starting to use the Digital Station for Calibration and Test

- **The testing and calibration should be performed by qualified technicians with specific knowledge.**
- **Only start operation of the Calibration Digital Station after reading and understanding this manual.**
- **Always use a digital station with calibrated / certified indicators.**
- **Make sure before the start of each service, that the regulating and blocking valves are in the proper position.**
- **Follow the instructions in this manual during testing.**
- **The attachment of the valves must be homogeneous in the three / four attachment points.**
- **The valve may generate high noise levels.
People exposed must be provided with suitable protections.**
- **The opening of the valve can cause fluid projections.**
- **The installation must be designed to limit the access next to the test valve.**
- **Observe the company safety instructions on this case.**
- **Do not loose the mounting screws, hoses and valve parts when the system is pressurized.**
- **The Calibration and Testing Station described in this technical manual is a device for use in specialized technical area. The user is responsible for configuration and selection of the instrument parameters. The manufacturer warns of the risks of occurrences with damage to both people and material goods, resulting from improper use.**

Index

1.0 - Introduction 3

1.1 - Technical Specifications 4

1.2 - Maximum Test Pressure x Nominal Valve Diameter 5

1.3 - Test Station Installation..... 6

2.0 - Description of the Safety Valve Calibration System 7

2.1 - Description of System Elements 11

3.0 - Drawings 12

3.1 - Flow Chart 12

3.2 - Control Panel..... 13

3.3 - Dimensions..... 14

4.0 - Operation..... 15

4.1 - Fixing the valves to the test table:..... 15

5.0 - Operation of the Safety Valve Testing System 21

5.1 - Starting the Pneumatic Valve Calibration Test..... 22

5.1.1 - General Guidelines 22

5.2 - Testing a Safety Valve:..... 23

6.0 - Using the DMY-2097-PSV Digital Indicator 24

7.0 - Configuring the Serial-to-Ethernet Device Server 31

8.0 - Battery Charger 35

9.0 - Battery Indicator..... 36

10.0 - Maintenance..... 37

10.1 - Battery charging PCB - parts identification 37

10.2 - Battery care and specifications..... 38

10.3 - Battery Replacement: 39

10.4 - Digital Sensors Connectors..... 41

11.0 - Appendix..... 43

1.0 - Introduction

The PSV Portable Test Station is designed to calibrate and test safety valves. It is composed by a digital pressure measurement system of high accuracy, and the pressure regulation system is equipped with regulating precision valves.

It is designed to operate with several flange diameters (up to 8") with manual attachment system and threaded valves up to 2".

The DMY-2097-PSV digital indicator simultaneously indicates the pressure value on the valve and the values found for valve closure / opening.

Easy operation, with the pressure system diagram printed on the control panel, with shut-off valve for the test supply circuit, needle valve with non-rotating stem, hardened stainless steel, which provides sealing and long service life, for fine adjustment and relief control.

1.1 - Technical Specifications

Testing Pneumatic Pressure	Up to 350 bar (5080 psi), (maximum pressure is limited by the digital indicator)
Accuracy	± 0.1 % of full scale (using Presys Digital Indicator)
Power Supply (Battery Charger)	100 to 240 Vac 50/60 Hz
Output (Battery Charger)	27.2 Vdc; 4.42 A maximum
Battery Pack Lithium Polymer (Li-Po)	Nominal Voltage : 22.2 Vdc Max. Current: 4.2 Ah Max. Capacity: 93.2 W.h
Electric Power	5 W
Mounting Type	Portable
Dimensions (Suitcase)	470 mm x 357 mm x 176 mm (WxDxH)
Dimensions (Test Table)	542 x 530 x 210 mm (WxDxH)
Height under clamps	0 to 130 mm / 5.1"
Valve Fixing System	Manual fixing with four clamps
Weight (Suitcase)	10 kg
Weight (Test Table)	22 kg

- Two 1.5 m hoses, 1/4" JIC with 1/4" NPT male adapter, 10150 psi working pressure, 23200 psi burst pressure.
- Engineering units for DMY-2097-PSV (Digital Indicator): psi, atm, inH₂O, kgf/cm², mH₂O, inHg, mmHg, cmHg, bar, mbar, kPa, mmH₂O, gf/cm², Pa, MPa;
- Provided with 5 adapter sizes for threaded NPT female valves: ½", 1", 1 ¼", 1 ½" and 2". Maximum pressure up to 350 bar (5080 psi);
- Set of Flanges Adapters for flanged valves: ½ "(DN 15) up to 8" (DN200), with a set of sealing O-rings, plus set of spare O-rings;
- Gas test supply input: ¼" NPT female connection up to 350 bar (5080 psi);
- The indication of the supply pressure for the test valve is shown by an auxiliary analog pressure gauge;
- ¼" NPT female quick connector for an external standard pressure gauge. It allows the connection and removal of pressuregauges with NPT thread without the use of tools.

External standard pressure gauge not supplied.

1.2 - Maximum Test Pressure x Nominal Valve Diameter

Maximum Test Pressure								
bar (kPa)	10 (1000)	20 (2000)	30 (3000)	50 (5000)	70 (7000)	150 (15000)	210 (21000)	350 (50000)
DN 25 (1")	X	X	X	X	X	X	X	X
DN 50 (2")	X	X	X	X	X	X	X	X
DN 80 (3")	X	X	X	X	X	X	X	
DN 100 (4")	X	X	X	X	X	X		
DN 125 (5")	X	X	X	X	X			
DN 150 (6")	X	X	X	X				
DN 200 (8")	X	X	X					

Table 1 - Pressure Limits x Valve Diameter



Warning:

Never exceed the maximum recommended pressure for the valve diameter, according to the table above.

Risk of damaging the fixing system and the test table.

Risk of accident with injuries to the operator and people close to the station.

Never use the valve fixing system that shows wear or mechanical deformation.

Whenever possible, use the 4 fixing clamps, especially at higher pressures.

More details about the fixing system in item 4.1.

1.3 - Test Station Installation

The following resources are required to install the test station:

- 110/220 Vac socket with grounding (to recharge the battery when necessary);
- Air / N₂ line up to 350 bar for testing safety / relief valves;
- The pneumatic connections on the Suitcase and Test Table are 1/4" NPT threads.

PRESYS

2.0 - Description of the Safety Valve Calibration System

The controls and valves for operating the PSV testing system are composed by the following elements:

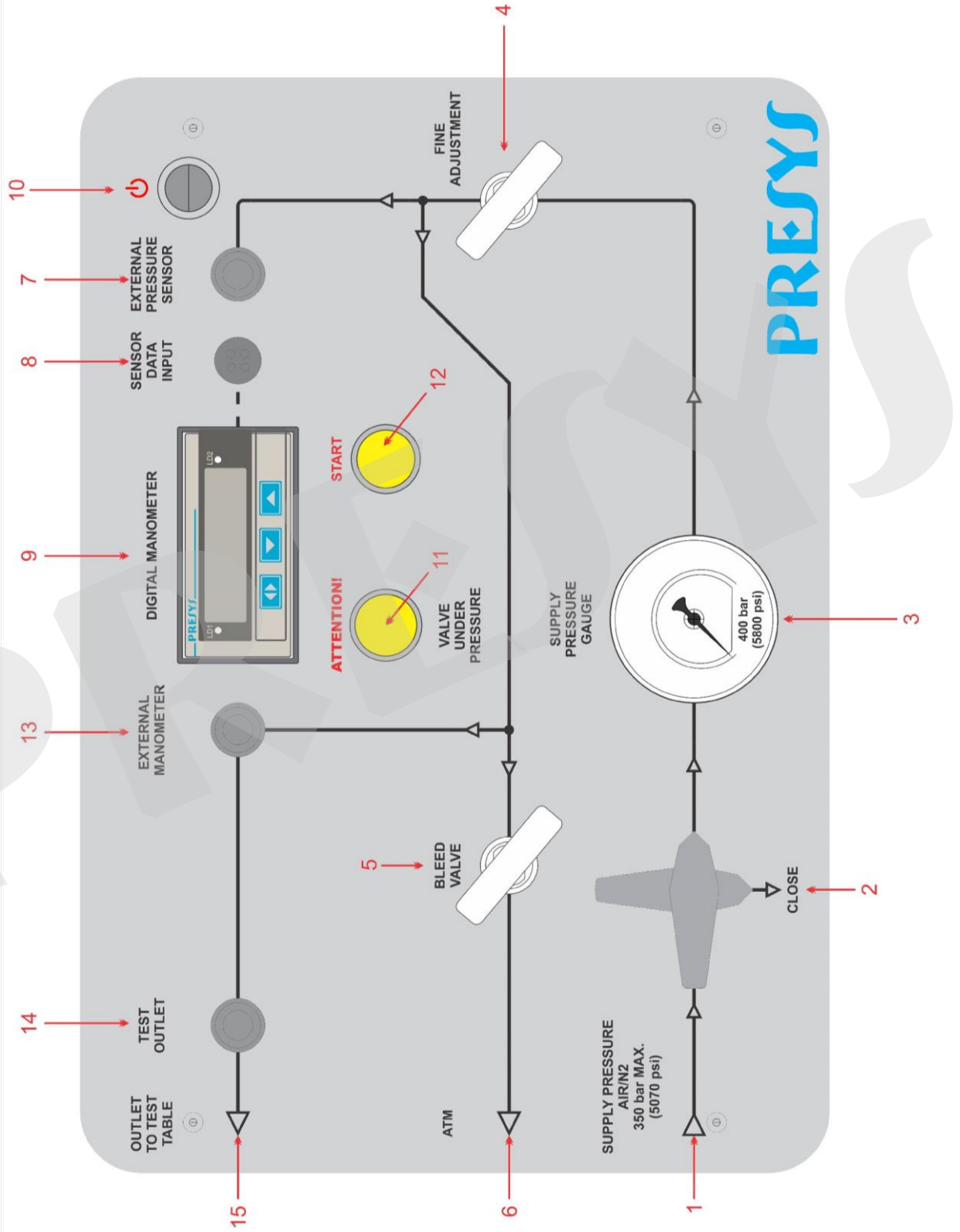

Fig. 1 - Suitcase Control Panel



Fig. 2 - Suitcase left side view



Fig. 3 - Suitcase rear view (details)

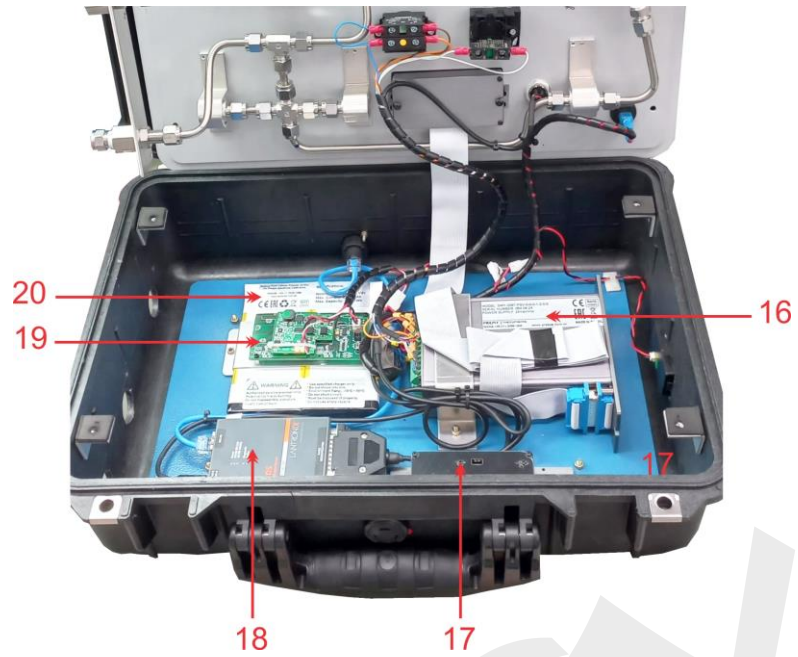

Fig. 4 - Suitcase Internal View



Fig. 5 - Test Table Front View



Fig. 6 - Test Table Rear View

2.1 - Description of System Elements

- 1) Gas Test Supply Inlet, 1/4" female NPT connection 350 bar (maximum) AIR / N₂ high pressure supply connection, at the left side of the suitcase;
- 2) Shut-off Valve from Gas Test Supply Inlet;
- 3) 400 bar pressure gauge, supply pressure indicator for gas testing, available for calibration. In the latest versions, this gauge is digital; it remains on even when the on/off switch is turned off. The digital gauge has the following units of measurement: bar (standard unit), kgf/cm², psi, MPa, and kPa.
- 4) Needle valve for regulating the air flow for PSV valve actuation test (FineAdjustment);
- 5) Needle valve to relief air pressure from the system after test (Bleed Valve);
- 6) Bleed Valve Output to Atmosphere, 1/4" female NPT. **Keep this output always opened;**
- 7) Connector for the External Pressure Sensor 1/4" NPT female. **Carefully check the range of the transmitter before pressurizing;**
- 8) Sensor Data Input;
- 9) Digital Manometer Display, that performs the indication of the pressure actuation points, according with the range of the pressure transmitter;
- 10) On/Off button for the Portable Test Station;
- 11) Warning Light for pressurized valve (it will be ON if pressure is above 1 bar);
- 12) START button of the digital manometer, with the Start, Stop and Acknowledge (ACK) functions of the test cycle;
- 13) External Manometer (supplied by the customer), 1/4" female NPT quick connection;
- 14) Test outlet for small valves, 1/4" female NPT quick connection;
- 15) Gas Output to Test Table;
- 16) DMY-2097-PSV Digital Indicator of the Pneumatic System, with pressure indication shown in PI-02;
- 17) RS-485 PSV Interface, connected to the Digital Indicator;
- 18) Serial-to-Ethernet Device Server, connected to the RS-485 PSV Interface;
- 19) Battery charge PCB;
- 20) Battery Pack Lithium Polymer (Li-Po);
- 21) Battery Indicator, on the rear side of the suitcase;
- 22) RJ-45 Ethernet Connector (on the rear side of the suitcase) for the communication of the digital indicators with the ISOPLAN PSV-5 software;
- 23) Battery Charger connector; on the rear side of the suitcase;
- 24) Test Flange on the Test Table;
- 25) Gas Inlet on the Test Table (connected to the suitcase outlet).

3.0 - Drawings

3.1 - Flow Chart

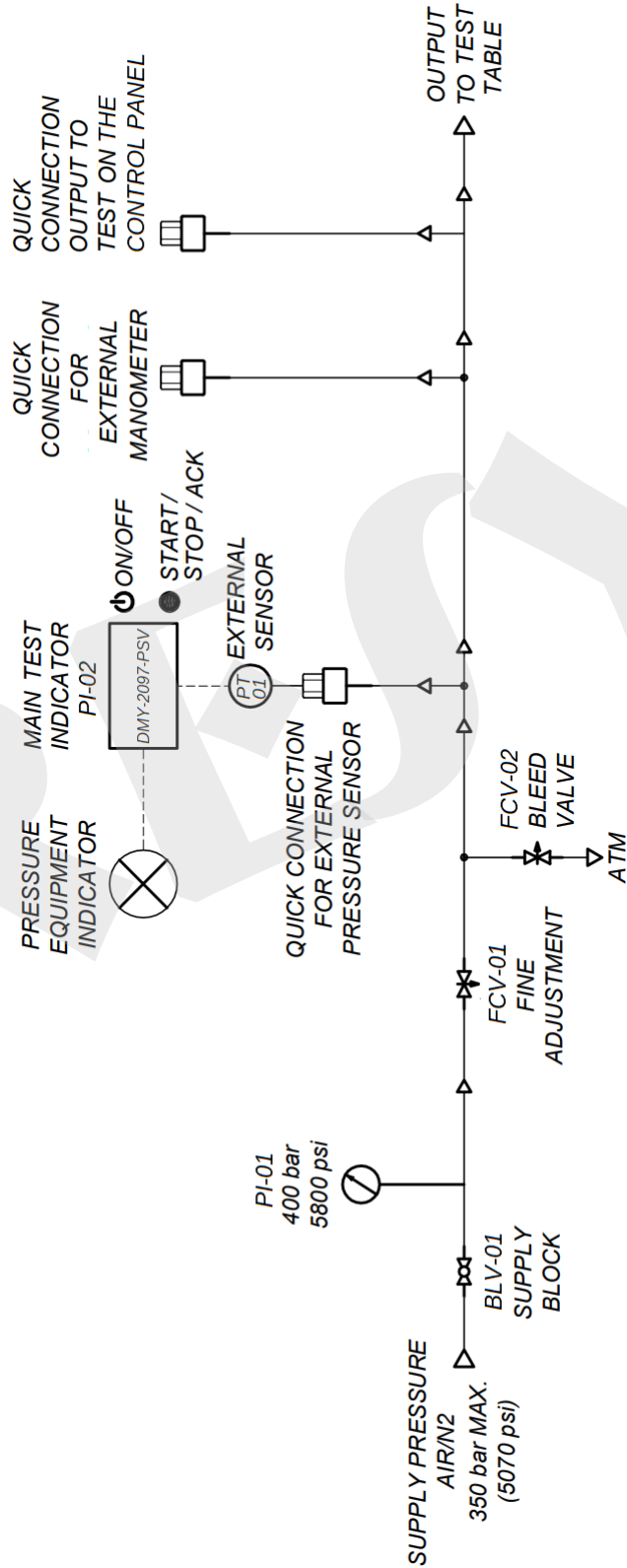

Fig. 7 - Flow Chart

3.2 - Control Panel

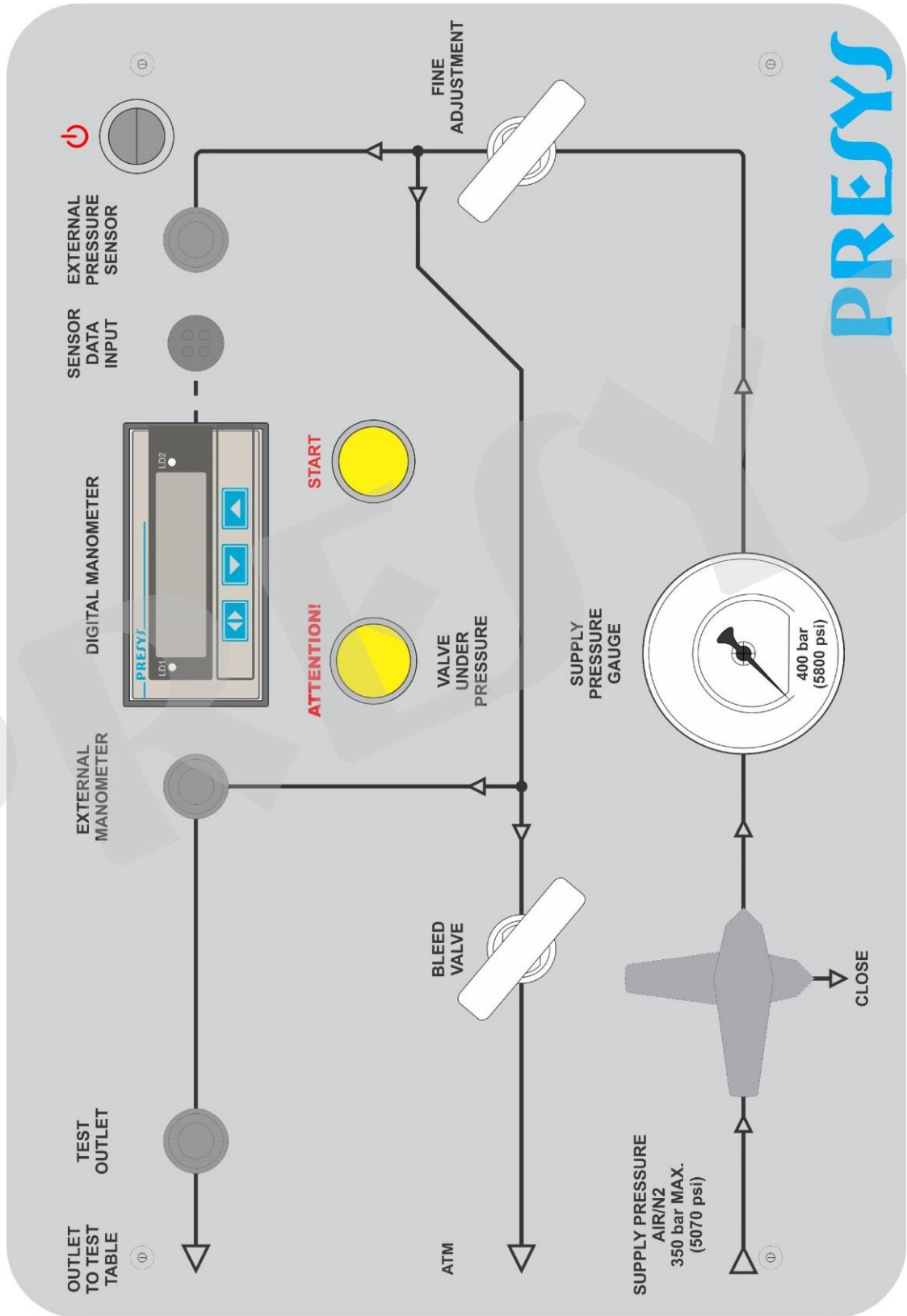

Fig. 8 - Control panel

3.3 - Dimensions



Fig. 9 - Dimensions

4.0 - Operation

Before operating the equipment, the initial status of the components of the PSV Portable Test Station must be observed:

- **Battery charger power supply from 100 to 240 Vac with grounding;**
- **Turn on the suitcase electrical devices by using the on / off switch on the panel;**
- **Check that the pressure of the valve to be tested is compatible with the external pressure sensor connected to the digital indicator;**
- **Always work safely, using the personal protection equipment required for the job;**
- **Be sure that the valve under test is correctly fixed to the test table;**
- **Never exceed the maximum pressures of the test station and of the external pressure sensor;**
- **Always check that the system is depressurized before removing the tested valve.**

4.1 - Fixing the valves to the test table:

Threaded Valves

The test on valves with $\frac{3}{4}$ " male NPT threads, can be performed directly on the connection on the table.

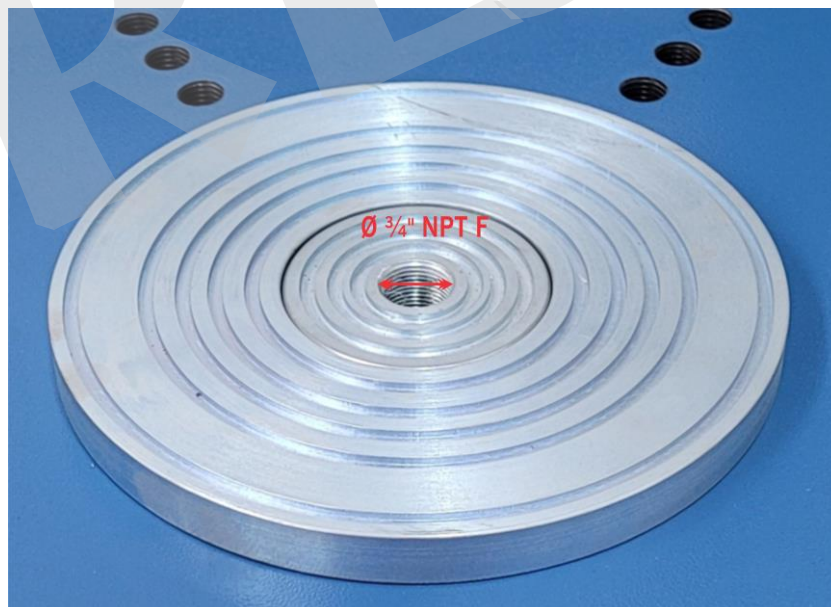

Fig.10 - Central flange with $\frac{3}{4}$ " female NPT thread

For other measures of threads, use the adapters for screw valves that were delivered with the test station: 5 x 3/4" nipples and reduction gloves with the following measures: 1/2", 1", 1 1/4", 1 1/2" and 2", manufactured in carbon steel.

Maximum working pressure: 350 bar (5000 psi).



Fig. 11 - Adapters for female NPT threaded valves

When using thread sealing tape, avoid applying the tape to the first few threads. Always prevent thread tape or solid particles from falling inside the valves under test.

- **Flanged Valves from 1/2”(DN15) to 8” (DN200).**

The system for attaching flanged valves to the station table is composed of screw holes on the table, screws and clamps.



Fig. 12 - Inner screw



Fig. 13 - Fixing clamp and support screw

The screws are made from high tensile strength Class 12.9 forged steel, ensuring that the valves are properly secured to the test table.

The maximum tightening torque of the suggested fastening system nuts is 597 N.m.

Use the M22 ratchet wrench to tighten the nuts.

Whenever possible, use the four fixing clamps.

Always check that the valve and clamps are centered and symmetrical in relation to the flange and valve to be tested.

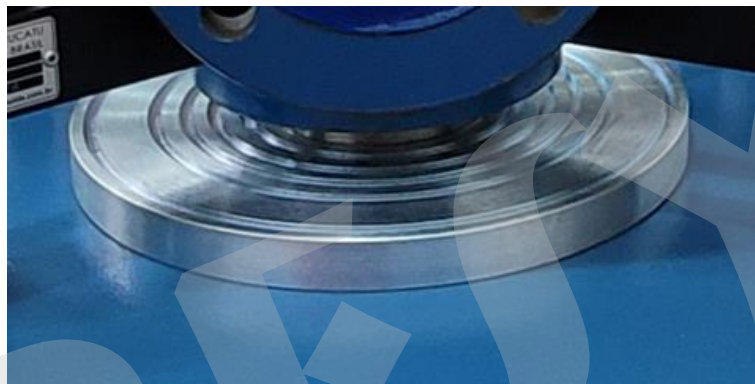

Fig. 14 - Valve detail centered on the flange



Fig.15 - Valve and centralized clamps

The clamp must be in a horizontal position in relation to the table, adjusting the level by means of the support screw if necessary.



Fig. 16 - Detail of the positioning of the fixing system

The inner screws of the clamps must be as close as possible to the flange in the case of flanged valves.

Ensure that the nuts and fixing clamps are tight. The maximum recommended torque for the M22 screw is 597 N.m.

Never position the valve's discharge/outlet flange towards you.

It is important to check the maximum test pressure with the diameter of the valve inlet flange. See Table 1.

Never exceed the maximum pressures recommended for the valve diameters in the table above. Risk of damaging the valve clamping system, the calibration table and causing injury to people using or near the test bench.



Never use components for attaching valves to the table that show signs of mechanical deformation.

Selecting the flange adapter

The central flange of the test station allows it to be used with flanged valves with RF flange, as shown in the following figures:

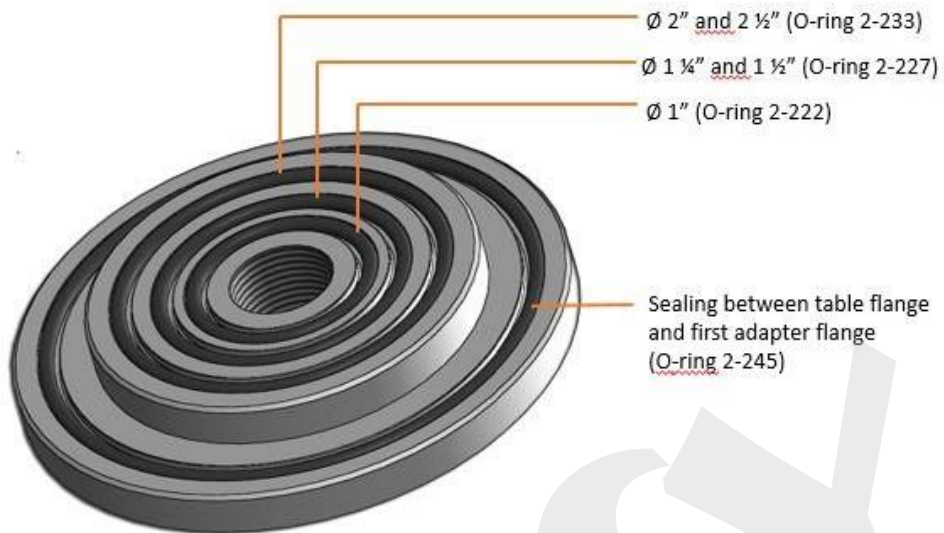

Fig. 17 - Central flange

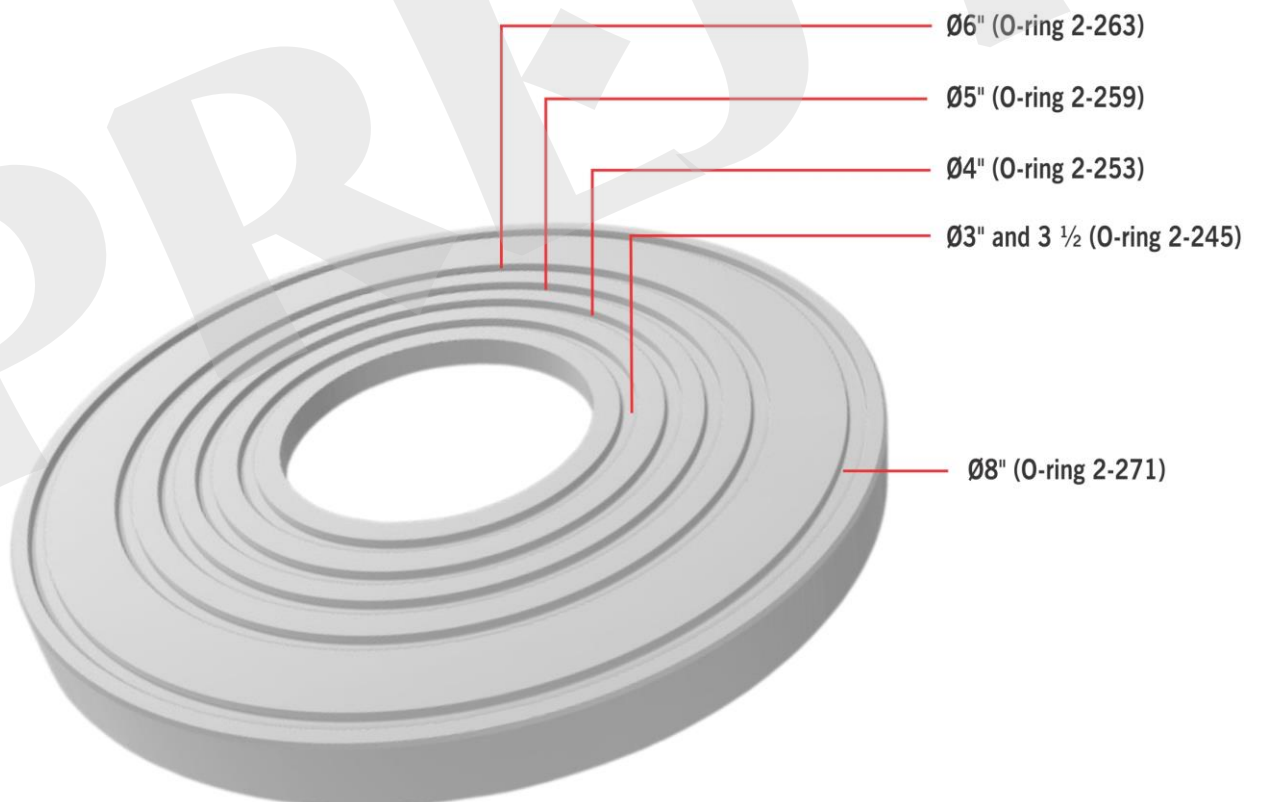

Fig. 18 - First RF flange adapter

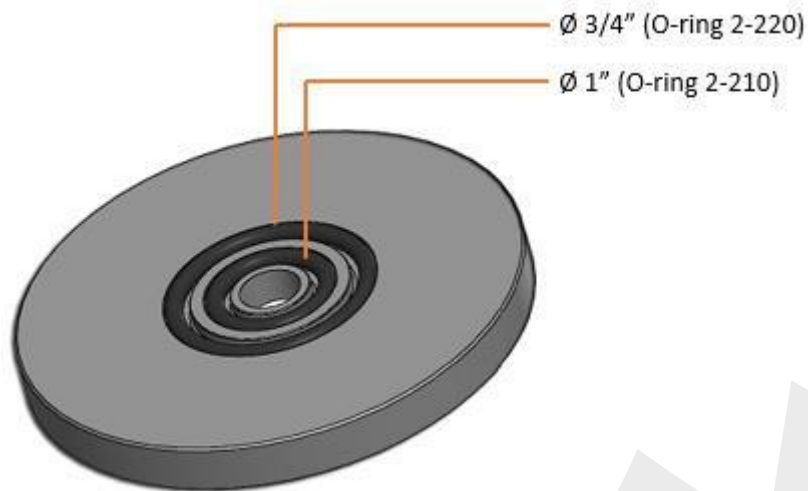

Fig. 19 - RF flange adapter

The smallest adapter flange for $\frac{3}{4}$ " and 1" valves must be mounted on the fixed flange of the table, using all the O-rings on the test table.

The test station is provided with two complete sets of 90 Shore O-rings.

The O-ring models can be found in the appendix at the end of this manual.

5.0 - Operation of the Safety Valve Testing System

Initially it is necessary to check the size of the valve to be tested and use the appropriate flange adapter to mount it on the test table.

Use the O-rings in the channels corresponding to the valve flanges used.

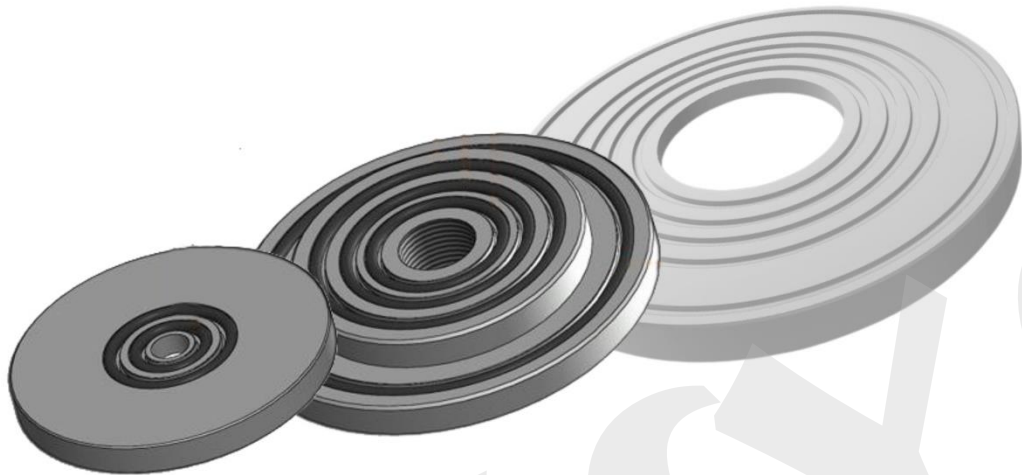

Fig. 20 - RF flange adapters

Place the valve carefully on the table's flange so as not to damage the sealing O-rings, in a position centered on the table.

Position the inner screws as close as possible to the valve flange and ensure that they are tightened securely with their nuts and clamps.

See the previous chapter for more details.



Fig. 21 - Valve fixed to the table

5.1 - Starting the Pneumatic Valve Calibration Test

5.1.1 - General Guidelines

Initial position of the valves on the test table and control panel using pneumatic supply of N2 or high pressure air:

1. Turn on the digital indicator PI-02;
2. BLV-01 - Close position;
3. FCV-01 - Closed, turn in clockwise;
4. FCV-02 - Closed, turn in clockwise;
5. Close the test outlet and external manometer output if not used.

Note: **Keep the Bleed Valve Output always opened to the atmosphere**

5.1.2 - Functional description and general guidelines:

- 1) Mount the Safety Valve to be calibrated, making sure that it is centered on the test table and that the clamp screws are as close as possible to the flange, in the case of flanged valves, to avoid gas leakage and safety failures;
- 2) When the valve (BLV-01) is opened, the system is supplied by the high pressure gas test inlet;
- 3) The fine adjustment needle valve (FCV-01), when opened, increases the pressure in the valve under test and must be closed when it reaches the set pressure. **Be careful not to exceed the maximum pressure of the external pressure sensor;**
- 4) To decrease the pressure, use the needle valve (FCV-02);
- 5) Before removing the calibrated safety valve, close the needle valve (FCV-01), and drain the pressure under the valve tested by the needle valve (FCV-02);
- 6) Make sure there is no pressure in the test flange, before removing the calibrated safety valve, observing the "Valve under pressure" signal lamp is off.

5.2 - Testing a Safety Valve:

Steps to run the test:

- 1) Position the valves according to item 5.1;
- 2) Open the BLV-01 shut-off valve and observe the supply pressure using the PI-01 pressure gauge;
- 3) Select the pressure unit on the DMY-2097-PSV digital indicator (PI-02), if necessary, according to the following steps:
 - a) Press the ▼(DOWN) key so that the current pressure unit shown in the display, then press ◀▶(ENTER) key and the current unit starts to flash;
 - b) Then use the ▲(UP) or ▼(DOWN) keys to change the pressure unit;
 - c) When pressing ◀▶(ENTER) again, the selected pressure unit is confirmed;
 - d) Then use the ▼(DOWN) to return to the pressure indication;
 - e) If it is necessary to reset the pressure indication, keep the ◀▶(ENTER) key pressed and then press the ▼(DOWN) key, release both keys;
- 4) Press the Start button on the control panel;
- 5) Note that the display indicates the pressure reading, Led 1 (green) is on and Led 2 (red) is kept off, signaling the detection state of the maximum pressure peak that precedes the valve opening;
- 6) Open the FCV-01 needle valve slowly so that the system pressure rises gradually and the valve acts;
- 7) As soon as the valve acts, close the FCV-01 needle valve. The actuation of the valve under test may produce a very loud noise;
- 8) At this moment the indicator will detect the opening pressure (Set) and start the detection of the valve closing pressure (Reseating). Led 2 (red) is on, while Led 1 (green) is off;
- 9) After detection (aprox. 10s), the display on the indicator will show the opening and closing pressures of the tested valve; and Leds 1 (green) and 2 (red) are off;
- 10) In order to acknowledge the end of the test and to stop indicating the opening and closing pressures, press again the Start button on the control panel;
- 11) If you want to perform another test, slowly open the FCV-02 bleed needle valve and reduce the pressure inside the valve to a value below its opening setpoint;
- 12) Repeat steps 4 to 11;
- 13) If you want to remove the valve from the test table, fully open the FCV-02 valve until the pressure under the valve is zero;
- 14) Observing the “Valve under pressure” signal lamp is off;
- 15) Remove the tested valve.

6.0 - Using the DMY-2097-PSV Digital Indicator

The PSV workstation is designed for the test of Pressure Safety Valves (PSV) to detect the *set* (opening) and the *reset* (closing) pressure values. It can communicate with the Isoplan Calibration Software to document the PSV test results.

The indicator module installed inside the workstation provides two inputs for the pressure sensor (pressure transmitter) and the communication interface and one contact input for the START button. The following terminals are used:

Input	Terminals
Pressure Transmitter	1 (Tx/Rx+), 2 (Tx/Rx-), 8 (power supply +), 5 (power supply -)
Communication Interface	11 (Tx/Rx+), 12 (Tx/Rx-), 9 (power supply +), 10 (power supply -)
Contact (START)	3, 4

Operation Level

After power up, the indicator works in the Operation level. In this level, the display shows the pressure reading or the corresponding pressure unit. In order to change between these presentations, use the DOWN key. The PRESS mnemonic or the UNIT mnemonic is briefly shown before the display presents the pressure value or its unit.

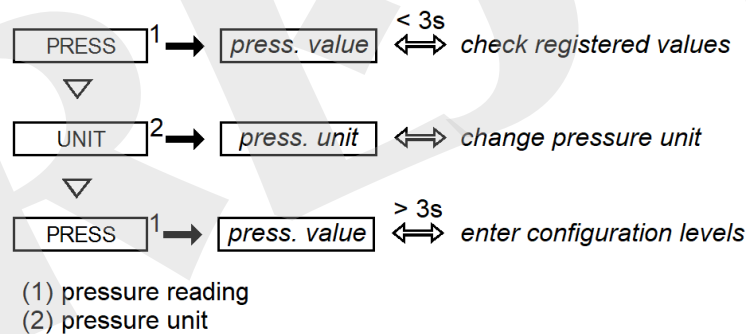
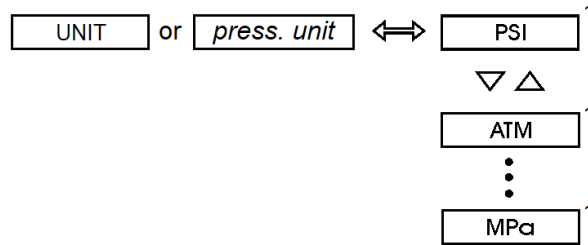

Fig. 22 - Pressure reading and unit in the Operation level.

If it is necessary to reset the pressure indication, hold the ENTER key and then press DOWN. It is possible to undo this operation by keeping ENTER pressed and then pressing UP. It is recommended to reset the indication before the start of a PSV test cycle, never during a running test. Note that there is a maximum pressure value allowed to be reset. This limit is set by the P.RST parameter of the INPUT configuration level.

The pressure unit can be changed in the Operation level while the PSV test is not in execution (stand-by state or State 1). When the UNIT mnemonic or the pressure unit is shown, press the ENTER key so that display starts to blink and the current pressure unit can be changed by the UP or DOWN keys. Press the ENTER again to confirm the new pressure unit.



(1) Only the pressure units selected in the UN.OP option of the GENERAL level are shown

Fig. 23 - Pressure unit selection in the Operation level.

PSV Test Cycle

The PSV test cycle is illustrated in figure below.

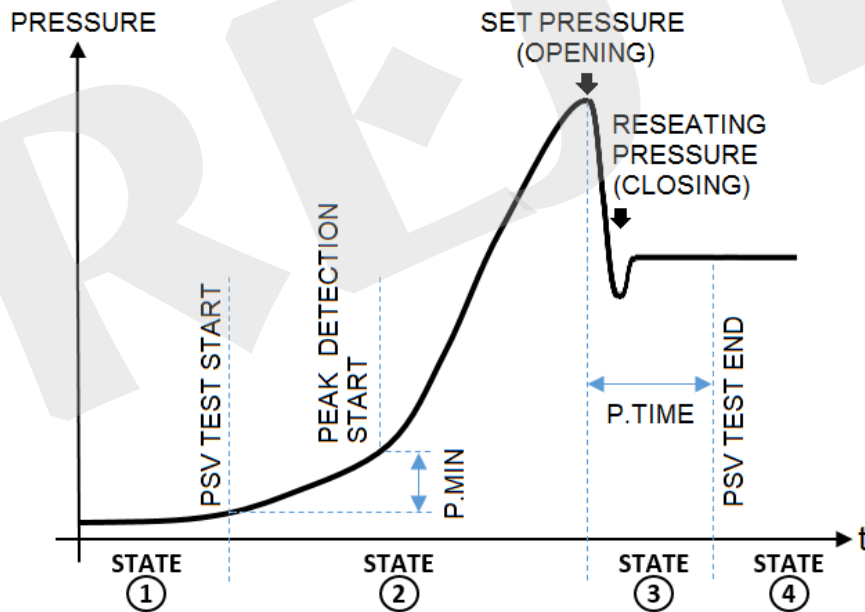

Fig. 24 - Test cycle of PSV valves.

In a complete PSV test cycle, the instrument follows four states that are identified by the indications on the display and by leds 1 (green) and 2 (red). Each of these states is described below. Note that the actual function associated with the START button of the workstation front panel depends on the state of the test cycle: START function for State 1, STOP for States 2 and 3, and ACKNOWLEDGE (ACK) for State 4.

State 1 - Stand-by state:

The instrument shows the current pressure reading or its corresponding pressure unit in the Operation level (see figure below). Leds 1 (green) and 2 (red) are kept off. The indicator waits for the beginning of the test cycle, moving to State 2, by pressing the START button of the on the workstation front panel.

When the indicator is executing other states of the test cycle, it can be brought back manually to State 1 by pressing again the START button to perform the STOP function (States 2 and 3) or the ACK function (State 4).

State 2 - Beginning of the test cycle and search for the Set pressure:

In order to enter State 2, the instrument must be in State 1 and the operator must press the START button on the workstation front panel or press the START button on the *Online Calibration* window of ISOPLAN. The display indicates the pressure reading, while led 1 (green) is on and led 2 (red) is kept off. The pressure applied to the valve must be continuously increased and the instrument starts to check the occurrence of the opening of the PSV valve at the corresponding maximum pressure peak (Set pressure). Note that in order to detect the set pressure its value must be greater than the sum of the initial pressure (measured at the instant State 2 begins) and the minimum pressure variation given by the P.MIN parameter of the P.TEST level.

State 3 - Search for the Reseat pressure:

After the opening of the PSV valve, the operator must stop applying pressure to the valve so that it can be closed again. The instrument starts searching for the minimum pressure value (Reseat pressure) that will make the valve close. During this state, led 2 (red) is on, while led 1 (green) is off. The instrument remains in this state for the time set by the P.TIME parameter in the GENERAL level. If there is any condition that causes the pressure to rise above the previously found maximum peak value, the instrument returns to State 2. Otherwise, at the end of the P.TIME interval, the minimum peak is recorded and the instrument moves to State 4.

State 4 - End of the test cycle and presentation of the pressure values detected:

In this state leds 1 (green) and 2 (red) are off and the display changes among the indications of the pressure reading (PRESS mnemonic), the Set Pressure (SET mnemonic) and the Reseat Pressure (RSEAT mnemonic). See figure below. The time intervals for the presentations of each of these three pressure values are configured by the parameters PRESS, SET and RSEAT of the INDIC option in the GENERAL level. In order to acknowledge the end of the test and return to State 1, press the START button for the ACK function.

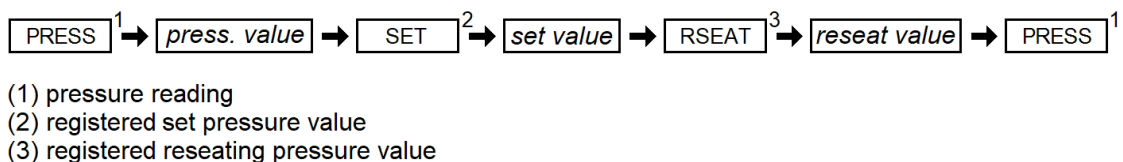

Fig. 25 - Display presentations during State 4 (end of test cycle)

At the end of each test cycle, the indicator registers both set and reseat pressure values. It can store up to 20 registers (see next figure). In order to view the registered values

in the Operation level, press ENTER for less than 3 seconds while the pressure reading (or the set/reseat pressure) is displayed. If there is at least one stored register, the REG.*n* mnemonic corresponding to the pressure values of the last test cycle will be shown, where *n* indicates the number of the register, from 1 to 20. Otherwise, the NO.REG (no registers) mnemonic is shown.

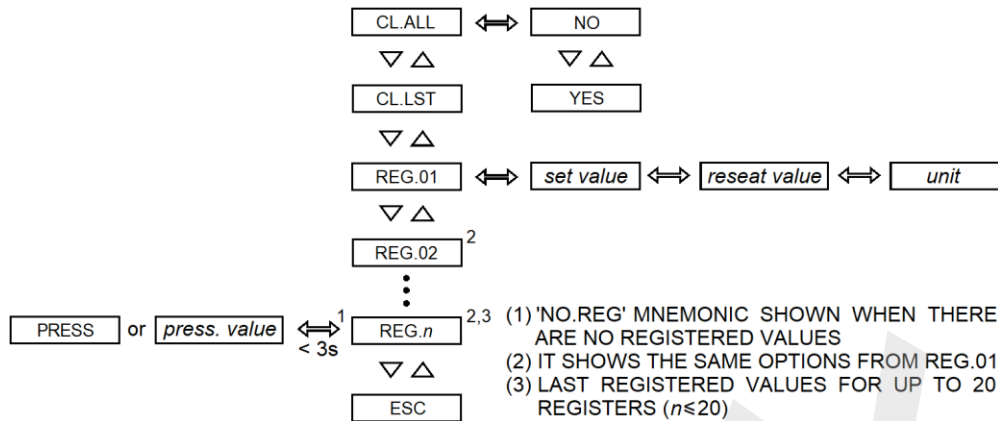

Fig. 26 - Registered Set and Reseat pressure values of PSV tests in the Operation level.

Each time a test cycle is completed, a register mnemonic is added to the list and the register number is incremented. After 20 registers have been stored, the pressure values obtained for subsequent test cycles will not be registered and the user will have to clear the last registers or all of them, as will be seen below.

The data assigned to each register consists of two pressure values (set and reseat) and the pressure unit. When pressing ENTER to select a register, the display shows the set pressure. Keep using the ENTER key to show the reseat pressure, the pressure unit, and finally to return to the register mnemonic REG.*n*.

Along with the mnemonics of the registers, there are the CL.ALL and CL.LST options. CL.ALL clears all registers stored and CL.LST clears only the last register. In order to apply one of these options, the user must select its mnemonic, then switch the NO mnemonic to YES by using the UP or DOWN key, and confirm by pressing ENTER.

Configuration Levels

To access the Configuration levels, press and hold the ENTER key for more than 3 seconds in the Operating mode. The parameters are distributed in three levels: INPUT, P.TEST and GENERAL.

INPUT Level

The INPUT level contains parameters associated with basic specifications of the pressure transmitter (sensor) and with the presentation of the pressure value in the operation level (see next figure).

DEC.PT: position of decimal point for the pressure indication shown in the Operation level (0 to 4 decimal places).

ADJ.PT: option used to enable or disable the automatic adjustment of the decimal point when the pressure unit is changed. The number of decimal places of the pressure indication is determined so that the maximum pressure value given in the new unit can be

shown with optimal resolution in the 5-digit display. The maximum pressure is considered to be given by the reference pressure shown by the P.REF mnemonic below. Note that the user can still alter the position of the decimal point in the DEC.PT option.

The P.REF and P.VERS mnemonics show information read directly from the pressure transmitter (sensor) at the moment it is connected to the indicator. The information assigned to these mnemonics is divided in two parts. Each part is shown by using the ENTER key. In order to return to the mnemonic, press ENTER again. If there is no transmitter connected to the indicator, the NO.SEN (no sensor) mnemonic is shown when P.REF or P.VERS is selected.

P.REF: reference pressure of the pressure transmitter (given by value and pressure unit)

P.RST: percentage (from 0 to 100%) of the reference pressure P.REF that defines the maximum reading pressure value allowed to be reset in the Operation level. That is, the pressure indication will be reset by the operator only if it is lower than the product P.RST (%) x P.REF (in pressure unit).

P.VERS: version of the pressure transmitter firmware (sequence of two four-digit values)

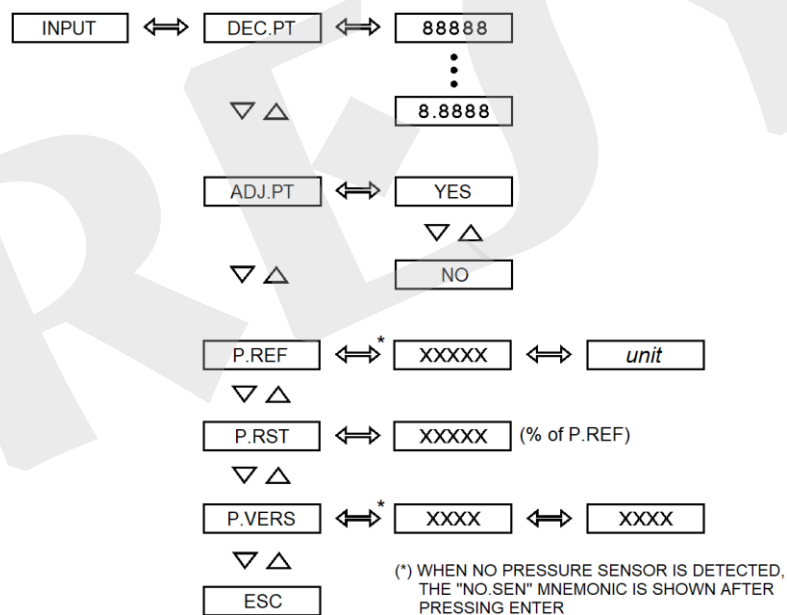

Fig. 27 - INPUT level options.

P.RST: specifies the maximum pressure that can be reset by the operator. It is given as the percentage (from 0 to 100%) of the full scale pressure of the sensor found in the P.REF option of the INPUT level.

P.RST: specifies the maximum pressure that can be reset by the operator. It is given as the percentage (from 0 to 100%) of the full scale pressure of the sensor found in the P.REF option of the INPUT level.

P.TEST level

Parameters for the PSV test cycle are configured in the P.TEST level:

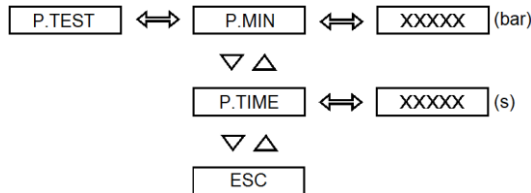

Fig. 28 - P.TEST level options.

P.MIN: minimum pressure variation (from 0 to 9999 in the current pressure unit), above the pressure read at the start of State 2 of the test cycle, required to detect the Set pressure value.

P.TIME: time interval (between 1 and 250 seconds) in which the instrument remains in State 3 and searches for the Reset pressure.

GENERAL Level

The following parameters are available in the GENERAL level:

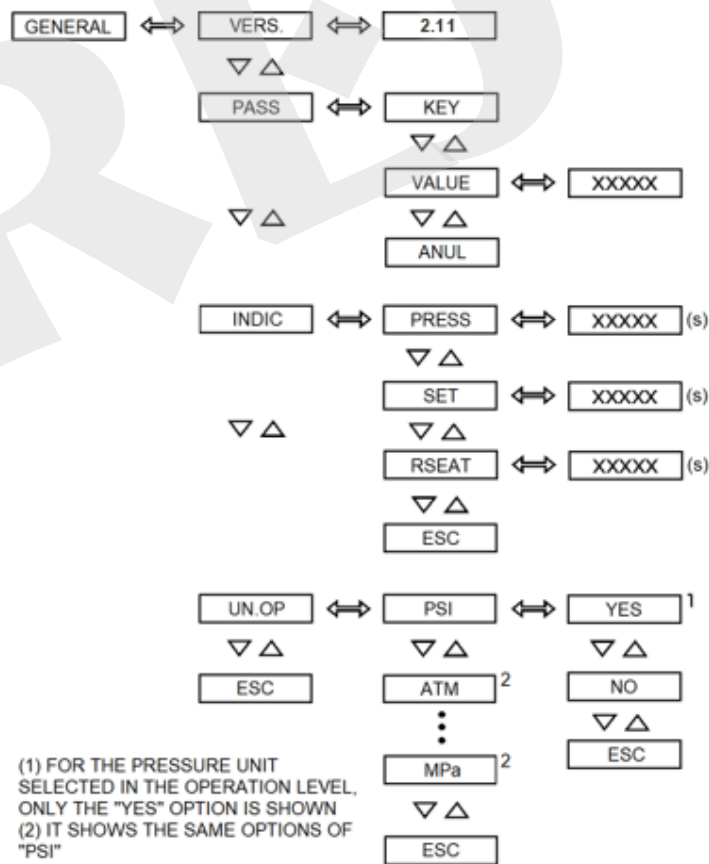

Fig. 29 - GENERAL level options.

VERS: indicator firmware version.

PASS: password request in order to access the configuration levels after pressing ENTER for at least 3 seconds in the Operation level. The password can be provided as the key sequence (KEY mnemonic), as a value (VALUE mnemonic) or both (by choosing KEY and VALUE, in sequence). The password the key sequence is UP, DOWN and ENTER, and the value password can be chosen by user between -9999 and 30000. The password system is disabled by selecting ANUL.

INDIC: time intervals (from 1 to 5 seconds) for the presentations of the current pressure reading (PRESS), Set pressure (SET) and Reseat pressure (RSEAT) shown in the Operation level after the end of a PSV cycle test (State 4). Note that the scanning of the three pressure indications ceases by pressing the START button (ACK function), so that the indicator returns to the stand-by state (State 1).

UN.OP: list of pressure units displayed in the Operating level. The presentation of each of the available pressure unit can be enabled or disabled. The available units are *psi* (**PSI** mnemonic), *atm* (**Atnn**), *inH₂O* (**inH2**), *mH₂O* (**nH2O**), *mmH₂O* (**nnH2**), *inHg* (**inHG**), *mmHg* (**nnHG**), *cmHg* (**cnHG**), *bar* (**bAr**), *mbar* (**nbAr**), *gf/cm²* (**G.Cn**), *kgf/cm²* (**kG.Cn**), *Pa* (**PA**), *kPa* (**kPA**) and *MPa* (**MPA**). Note that the pressure unit currently selected in the Operation level cannot be disabled.

Serial-to-Ethernet Device Server

In order to establish communication between a computer running the ISOPLAN software and the DMY-2097-PSV, the operator may be required to configure an address so that ISOPLAN can read/write the indicator registers.

The complete communication address provided from factory combines the type of protocol (Modbus-TCP), serial-to-ethernet device server IP address (192.168.0.2), the ISOPLAN port number (502), and the indicator Modbus communication address (1 for the pneumatic system indicator).

Thus, the address required by ISOPLAN for the DMY-2097-PSV indicator of the test bench is

modbustcp://192.168.0.2:502:1

Note: the IP address of the serial-to-ethernet device server can be changed for a different network by using the appropriate software from the manufacturer of the device server.

NOTE: Please refer to the ISOPLAN PSV-5 Technical Manual.

7.0 - Configuring the Serial-to-Ethernet Device Server

Follow the instructions below to change, if necessary, the IP address of the Serial-to-Ethernet Device Server (Lantronix Serial/TCP UDS 1100 IAP converter).

- 1) Install the UDS1100-IAP converter configuration application, **Lantronix DeviceInstaller 4.3.0.9**, from the CD sent with the test station, on a computer running Windows 10;
- 2) Connect a network cable to the RJ-45 Ethernet Connector on the rear of the test station and to the computer or network point on which the converter will work;
- 3) Power up the converter;
- 4) Run the *DeviceInstaller* application;

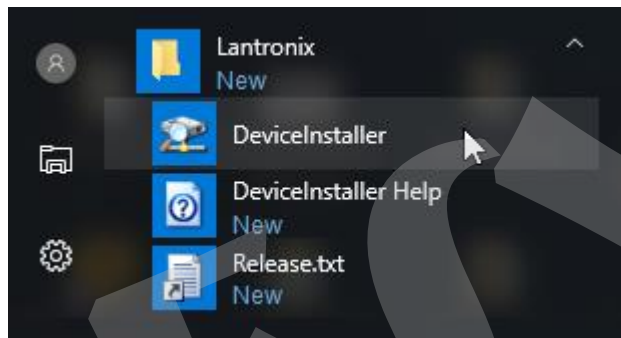

- 5) Click on *OK* if the following warning appears:

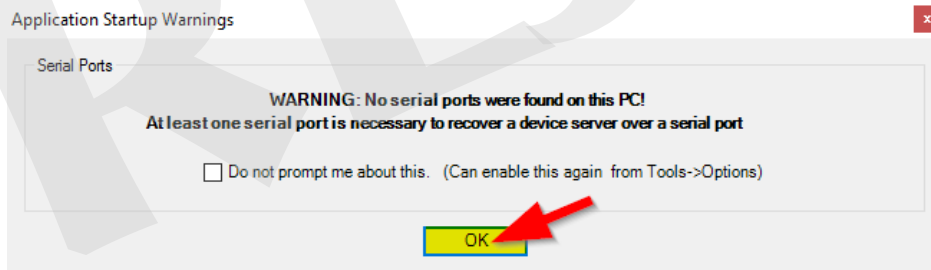

- 6) Click on *NO* if the following warning appears:

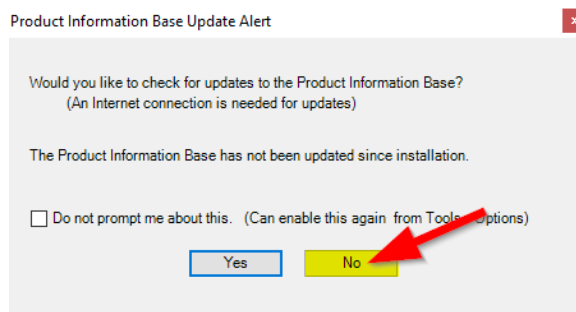

7) Click on *Search* and wait for the detection of the converter (device);

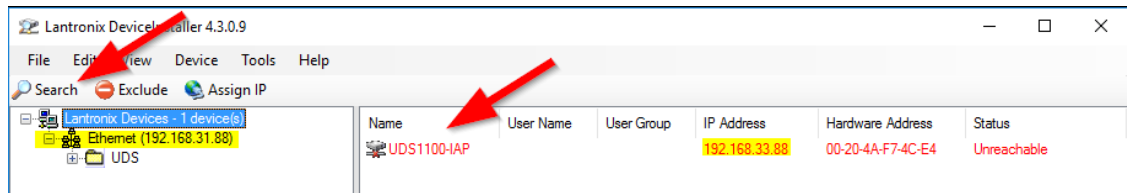

8) In the example below, on the left side of the window *Ethernet (192.168.31.88)* is the computer IP address, while on the right side the IP Address *192.168.33.88* is the actual address of the converter;

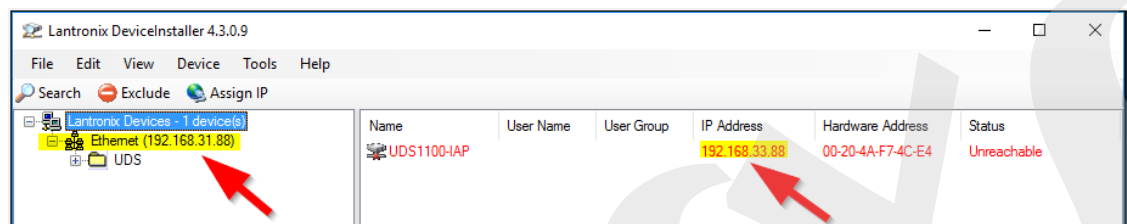

9) For the computer to access the converter’s communication data, it must be on the same network as the computer;

10) To change the IP address of the converter, click on *Assign IP*;

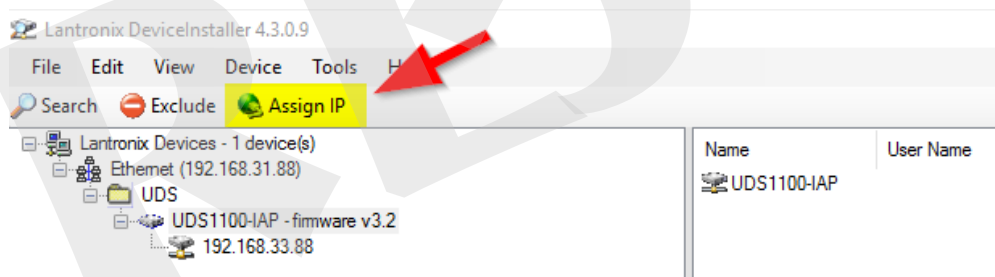

11) Select *Assign a specific IP address* and click on *Next*;



- 12) .Enter an IP address that is available on the network to which the converter will be connected and click on *Next* and then *Assign*;

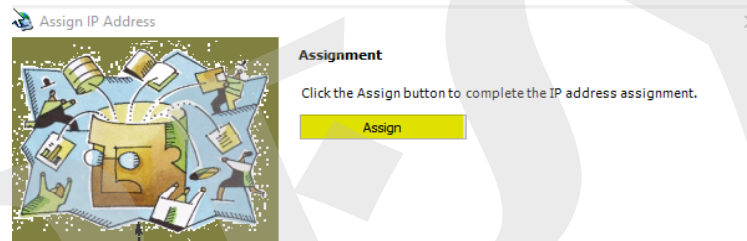
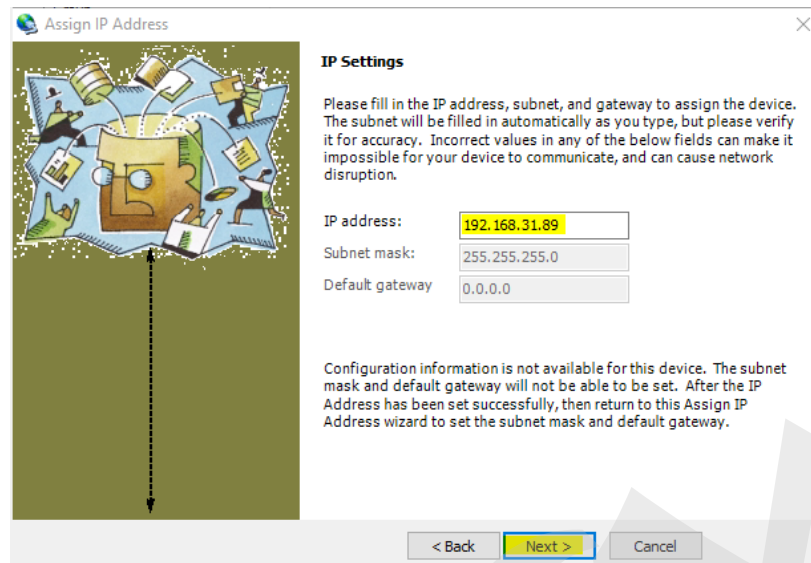

- 13) Wait for the task to progress and then click on *Finish*;

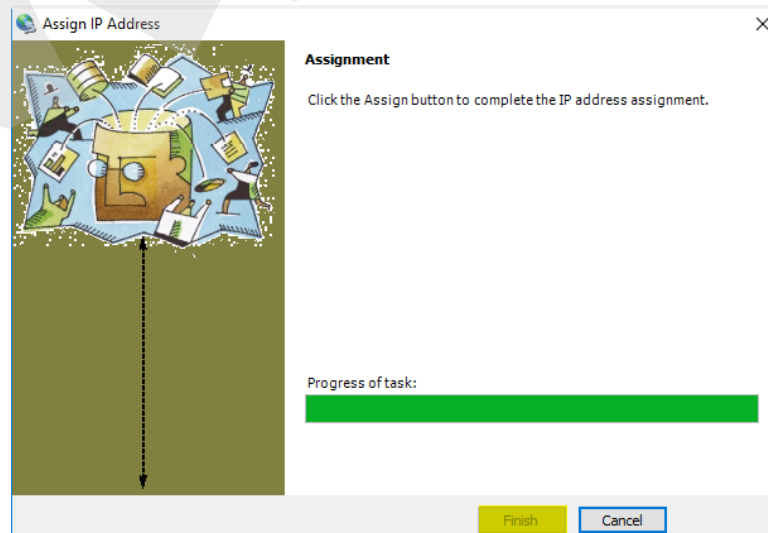

- 14) To check the settings, select the *Telnet Configuration* tab, click on *Connect* and press Enter:

```

Device Info | Configuration Records | Status Records | Web Configuration | Telnet Configuration
IP Address: 192.168.31.101   Port: 9999   Disconnect   Clear

*** Lantronix UDS1100-IAP Device Server ***
Serial Number   MAC address 0080A35D085D
Device ID: 00204A3ECQ3I8EFMUX6LT5E880TEESG
Software version V4.0.0.1 (191219) UDS1100

Press Enter for Setup Mode

Model: Device Server Plus+! (Firmware Code:UA)

Modbus/TCP to RTU Bridge Setup
1) Network/IP Settings:
   IP Address ..... 192.168.31.101
   Default Gateway ..... --- not set ---
   Netmask ..... --- not set ---
   Telnet config password set
2) Serial & Mode Settings:
   Protocol ..... Modbus/RTU,Slave(s) attached
   Serial Interface ..... 9600,8,N,1,RS485
   Modbus Port No ..... 502
3) Modem Control Settings:
   Modem control not available with RS422/RS485
4) Advanced Modbus Protocol settings:
   Slave Addr/Unit Id Source .. Modbus/TCP header
   Modbus Serial Broadcasts ... Disabled (Id=0 auto-mapped to 1)
   MB/TCP Exception Codes ..... Yes (return 00AH and 00BH)
   Char, Message Timeout ..... 00050msec, 05000msec
7) Security Settings:
   SNMP ..... Disabled
   Telnet Setup ..... Enabled
   TFTP Download ..... Enabled
   Port 77FEh ..... Enabled
   Web Server ..... Enabled
   Enhanced Password ..... Enabled
   Telnet Authentication ..... Disabled
8) Expert Settings:
   TCP Re-transmission timeout 500 ms

D)efault settings, S)ave, Q)uit without save
Select Command or parameter set (1..7) to change:
    
```

8.0 - Battery Charger



Fig. 30 - Suitcase Battery Charger

The Portable Test Station batteries are charged whenever the battery charger is connect, even if the Station is switched off.

There is a LED on the top of the charger to indicate when it is energized. When the LED lights up red it indicates that the battery is being charged with the nominal current (0.2 to 2 A Max, depending on the battery charge). When the LED is green it indicates that the current it supplies is zero or very low and that the battery is already charged.

Battery charger specifications:

Order Code: 06.03.0001-00.

Input Voltage: 100 ~ 240 Vac 50/60 Hz.

Output Voltage: 27.2 VDC 4.42A Max.

- Overload protection available (voltage, current and temperature).
- Provided with power cable, according to electrical standard used by the costumer.

9.0 - Battery Indicator

The battery indicator display is normally off, when pressing the button indicated on the figure below, it turns the display on for 10 seconds to indicates battery voltage and battery charge percentage.

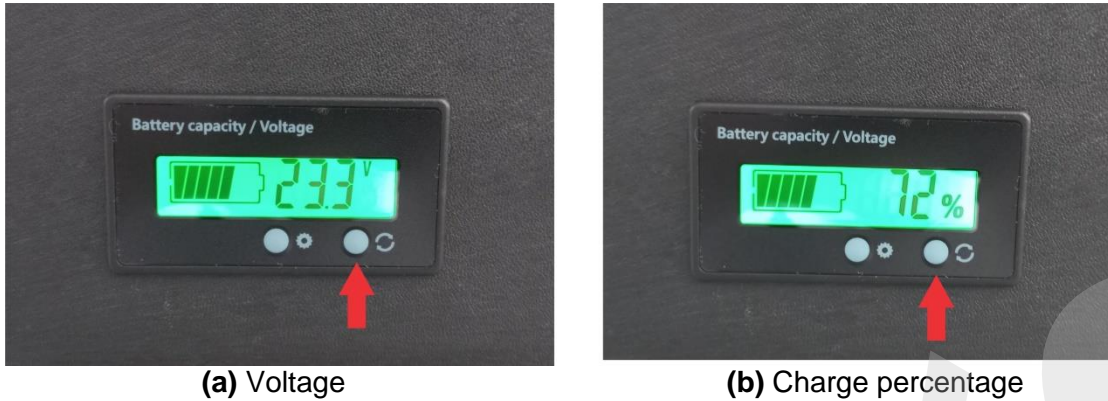

Fig. 31 - Suitcase battery indicator

Press the button once and the voltage and percentage indication alternates automatically.

The table below shows the relation between battery voltage and charge percentage:

Battery Voltage (V)	Charge Percentage (%)
25 to 27	100
24	88
23	66
22	44
21	22
18 to 20	0

Table 5 - Battery voltage and charge percentage

After the batteries are completely charged, the Test Station can be operated for approximately 12 hours.

Important! The battery symbol shown on the digital pressure gauge does NOT indicate the battery charge status of the portable PSV. It only indicates the power supply voltage level of the digital pressure gauge (3.3Vdc).



Fig. 32 - Digital pressure gauge.

10.0 - Maintenance

10.1 - Battery charging PCB - parts identification

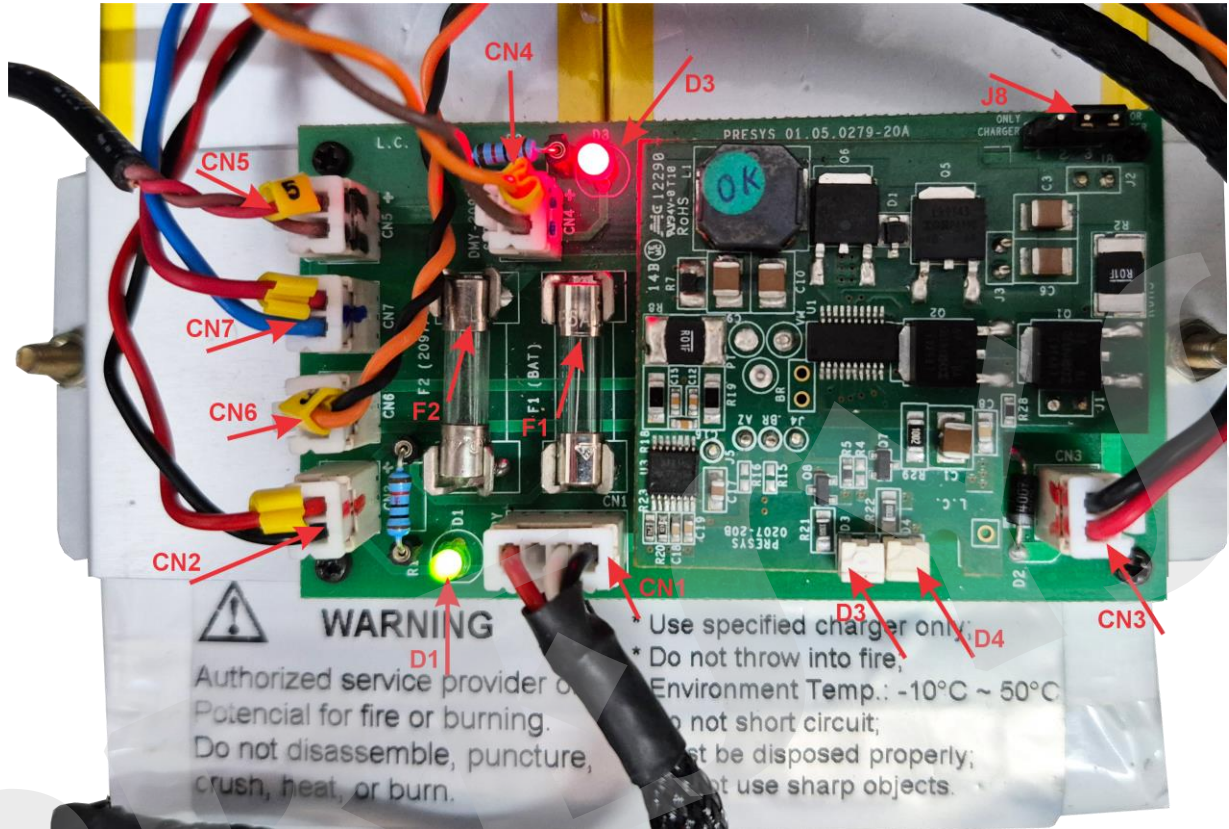

Fig. 33 - PCI Battery Charging

CN4 - Indicator Instrument-DMY-2097 Power Connector (19 to 27 Vdc depending on battery/charger voltage).

CN5 - Serial to Ethernet Adapter Power Connector (19 to 27 Vdc depending on battery/charger voltage).

CN7 - ON/OFF Button.

CN6 - Digital Manometer Power Connector (3,3 Vdc).

CN2 - Battery charge indicator Connector (19 to 25 Vdc depending on battery voltage).

CN1 - Battery Connector.

CN3 - Battery Charger extension cable connector.

D3 - (Cylindrical Red LED) - This indicates that the on/off button is on and the DMY-2097 and the Serial to Ethernet adapter are powered on.

D1 - (Cylindrical Green LED) - This indicates that Battery is connected, the brightness intensity changes according to the battery voltage.

D3 - Orange LED- (Square Body) - D3 lights up when the battery is being charged with the full current (approximately 2A) and turns off when the charging current reaches 10% of the maximum current (approximately 0.2A), indicating a full charge.

D4 - Green LED- (Square Body) - D4 indicates that the charger is connected. D4 lights up when the charger is connected and goes out when the charger is disconnected.

F1 - Battery Fuse (5 x 20mm, 5A Fuse).

F2 - Indicator Instrument-DMY-2097 and Serial to Ethernet Adapter Fuse (5 x 20mm, 1A Fuse).

J8 - Power selection jumper. Position 2-3 (BAT or CHARGER) is the default position, in this configuration the instrument can be powered by the battery or the charger. Position 1-2 (ONLY CHARGER) is the position used when have a problem with battery or charge PCB (BMS), in this position is possible to disconnect the battery and the instrument will powered by the charger only.

10.2 - Battery care and specifications



Warning:

Battery Pack Lithium Polymer (Li-Po) for Presys Advanced Calibrators

- Authorized service provider only
- Potential for fire or burning;
- Do not disassemble, puncture, crush, heat, or burn;
- Use specified charger only;
- Do not throw into fire;
- Environment Temp.: -10 °C ~50 °C;
- Do not short circuit;
- Must be disposed properly;
- **Do not use sharp objects.**

Specifications:

- Nominal Voltage: 22.2 Vdc;
- Max. Current: 4200 mAh;
- Max. Capacity: 93.24 Wh.

10.3 - Battery Replacement:

1 - Remove the 4 screws (M4 screws: 2 on the front panel and 2 on the left side). See figure 34.



Fig. 34 - Removal of the four M4 screws

2 - Carefully lift the front panel and rest it on the lid. Disconnect the battery from CN1, remove the two nuts (M4) that secure the battery clamp.

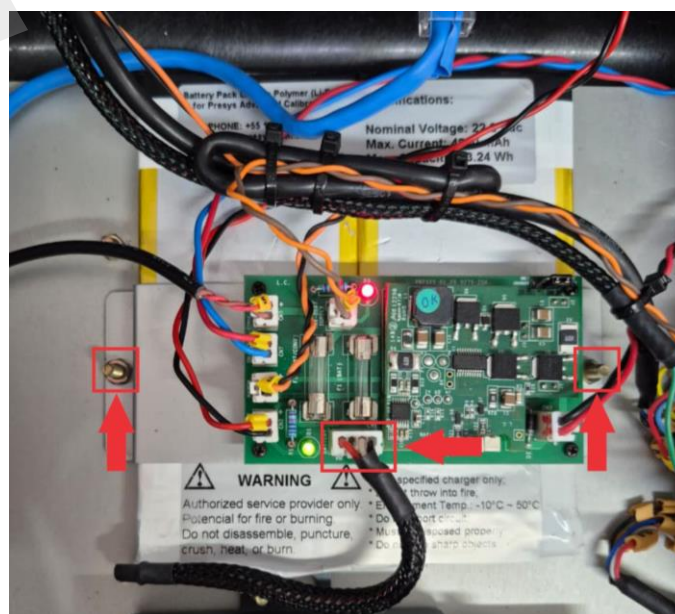

Fig. 35 - Front panel lifting and battery disconnection

3 - Lift the battery clamp, being careful not to stretch it or disconnect any cables. Remove the battery and position the new battery. Reattach the battery clamp, avoiding overtightening the nuts, and ensure the battery does not move.

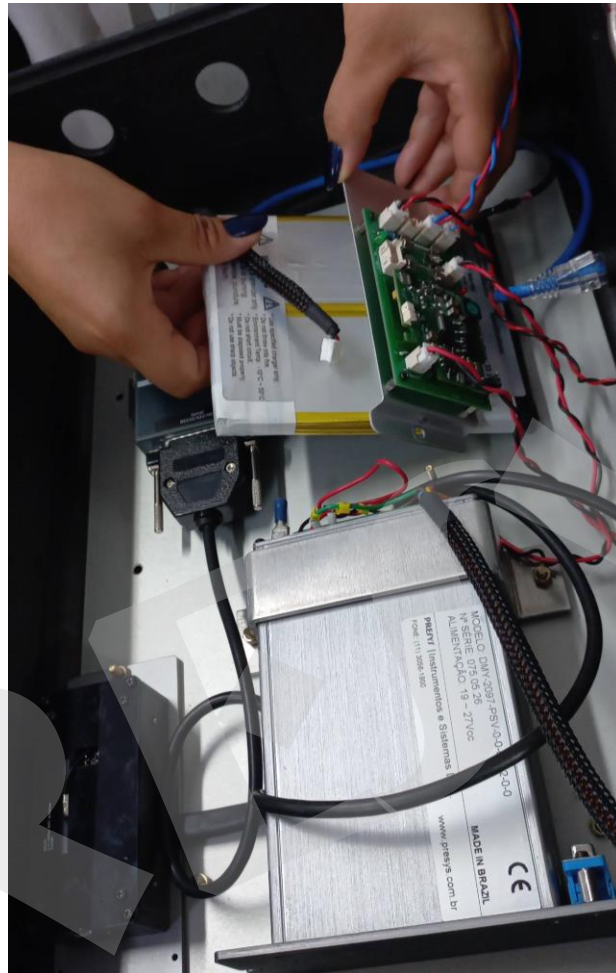

Fig. 36 - Battery replacement and clamp reinstallation

10.4 - Digital Sensors Connectors

Identification Parts:



Fig. 37

Sensor data input connector (PANEL)

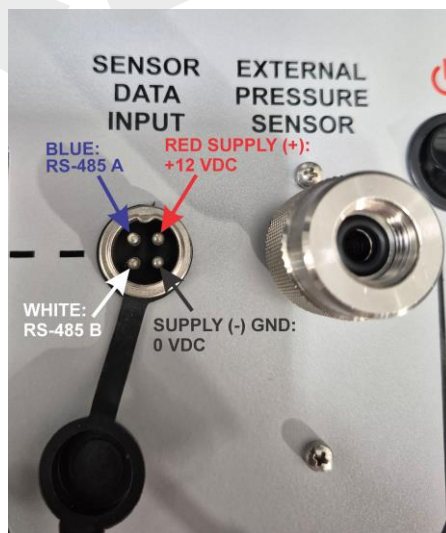

Fig. 38

The following voltages should be measured at the Sensor data input connector:

Between red and black is the digital sensor power supply; approximately +12Vdc ±1V should be obtained.

Between blue and white is the RS485 communication signal; a signal of $V_a - V_b = 2.5V$ is usually found without the digital transmitter.

Cable connectors

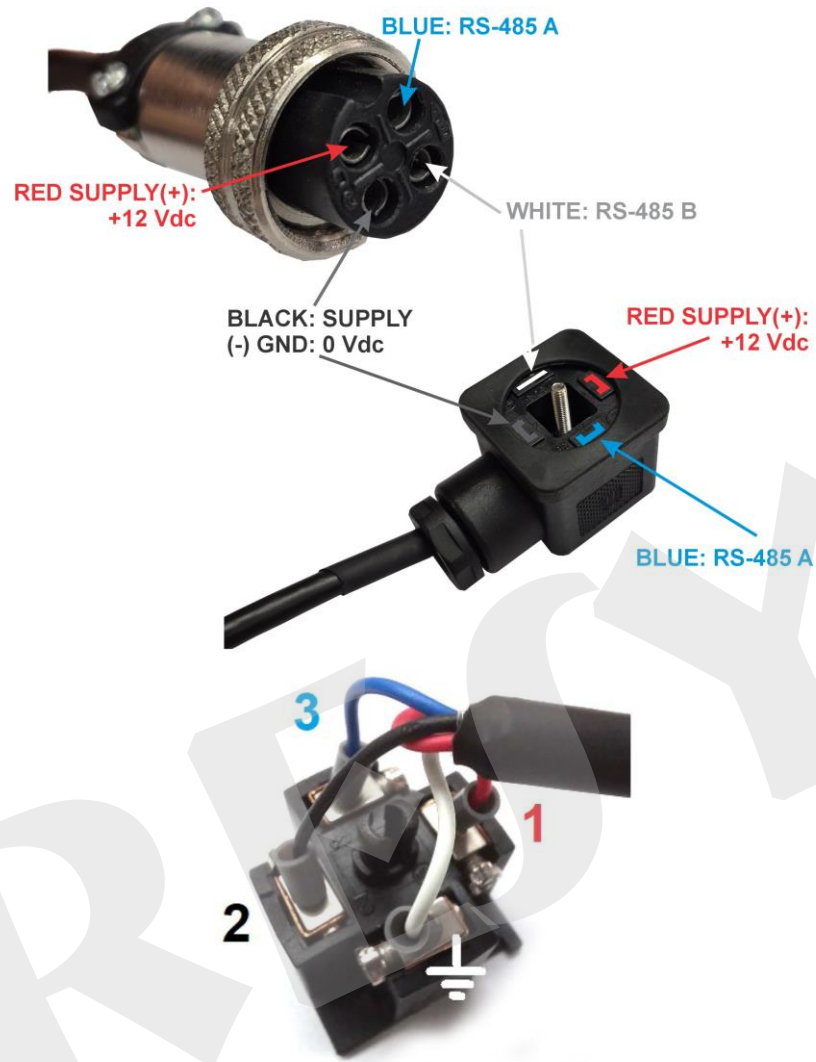

Fig. 39

Sensor connector

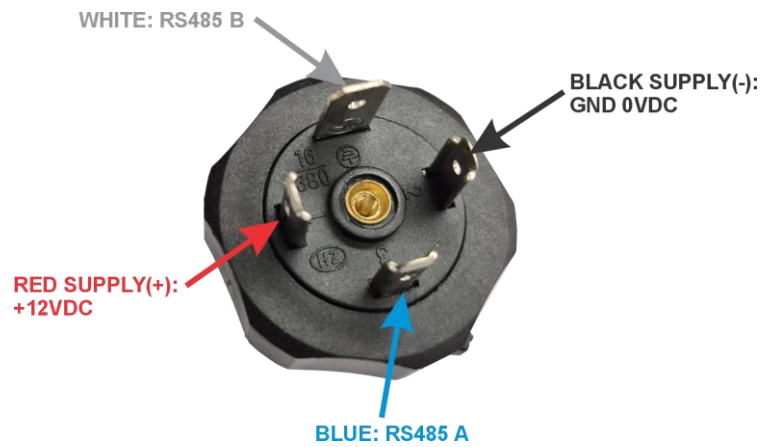

Fig. 40

11.0 - Appendix

Table 5 below shows the O-rings for RF (Raised Face) flanges provided with the test station:

FACED FLANGES SIZE	PART. N. O-RING (PARKER)	POLYMER	"SHORE A" HARDNESS
1/2"	2210	NITRILE RUBBER	90
3/4"	2220		
1"	2222		
1.1/4"	2227		
1.1/2"	2227		
2"	2233		
2.1/2"	2233		
3"	2245		
3.1/2"	2245		
4"	2253		
5"	2259		
6"	2263		
8"	2271		

Table 6 - O-rings for RF flanges

PRESYS